

DUTY PUMPS SERIES

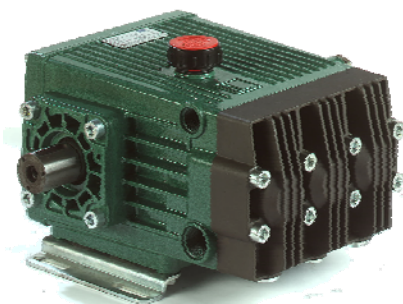

**Operating,
Set -up,
Service and
Safety
Instructions
Manual**

**LIGHT DUTY
Series**

GB



**IDROMECCANICA
BERTOLINI**
Reggio Emilia - Italy

Via Cafiero 20 42124 REGGIO EMILIA - ITALY

MANUFACTURER INFORMATION:

Manufacturer: IDROMECCANICA BERTOLINI S.p.A.
Via Cafiero 20
42124 REGGIO EMILIA - ITALY
Phone: +39 0522 306641 Fax +39 0522 306648
E-mail: email@bertolinipumps.com
Internet: www.bertolinipumps.com
www.chemicalpolypumps.com

Issued: December 2010
Edition: 00 June 2011

You have decided to show your preference for the "**BERTOLINI**" brand and have bought a product which has been manufactured with the benefit of the most modern technology and the finest materials, designed through research to ensure its improved quality, duration and functionality.

We thank you for the trust shown in our products.

Please read this booklet with care and always keep it within easy reach. You will find it useful in resolving any problem you may have with regard to the characteristics and functionality of the product.

Thank you for having chosen "BERTOLINI"

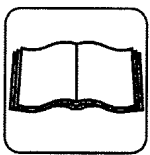

We at **Idromeccanica Bertolini** recommend that you read this Use and Maintenance Manual carefully before installing and using the pump. You should keep it within easy reach for any further reference. The Manual should be considered as an integral part of the pump itself.

Any person using the pump is expected to observe the relevant legislative provisions currently in force in the country where the pump is to be used. They are also required to follow the instructions set out in this Manual with care.





















TABLE OF CONTENTS

This Use and Maintenance booklet is made up of the following chapters:

1	GENERAL SAFETY RULES	Page 36
2	PRODUCT DESCRIPTION	Page 37
3	TECHNICAL SPECIFICATIONS	Page 38
	3.1 Identification of Components	Page 39
	3.2 Intended use	Page 40
	3.3 FAQ	Page 40
4	INSTALLATION – NORMS	Page 41
	4.1 Use with agricultural machines (Pump “P” series)	Page 41
	4.2 Use with motor/engine (Pump “PP” series)	Page 43
	4.3 Inlet Circuit	Page 44
	4.4 High Pressure Circuit	Page 45
	4.5 Installation diagram	Page 46
5	SETTING UP	Page 48
	5.1 Starting Procedure	Page 49
	5.2 Operation	Page 49
	5.3 Water leaks from seals	Page 49
	5.4 Pump Shut Down	Page 49
6	TROUBLESHOOTING	Page 50
7	WARRANTY	Page 51
8	ROUTINE SERVICE AND REPAIR	Page 52
	8.1 Crank gear and Lubrication	Page 52
	8.2 Check Valves	Page 52
	8.3 Packing/Seals	Page 54
	8.4 Plungers oil Seals	Page 55
	8.5 Shaft oil seals	Page 56
	8.6 Repair tools chart	Page 57
9	MANUFACTURER’S DECLARATION	Page 58

- d) This booklet complies with the state-of-the-art techniques at the date of the sale of the product and shall not be considered inconsistent for the sole reason it has been subsequently altered according to new experiences. **IDROMECCANICA BERTOLINI** reserves the right to up-date its products and related booklets without being forced to alter older products and booklets, but in cases exclusively required by safety reasons.
- e) The **“Bertolini Customer Service”** is available for any need arising when using or servicing the product, and for choosing related accessories.
- f) No part of this booklet can be reproduced without the written permission of **IDROMECCANICA BERTOLINI S.p.A.**

1- GENERAL SAFETY RULES

-  The high energy on the pressure jet is a source of serious dangers.
-  The pump must be used only by skilled personnel.
-  It is strongly recommended to fit mechanically pre-fastened high pressure hoses. They must be homologated for the Max. admissible pressure in the system, and they must carry over the stamping of the overpressure and the max. admissible temperature, besides the name of the producer and date of production.
-  Before starting check always your machine. Particularly check the integrity of plumbing, high pressure fittings, the gun trigger that should work in a soft way, without releases and immediately return to its position, when off.
-  Do not install defective high pressure hose and do not try to repair it, rather replace it by an original spare part.
-  Keep children and animals away from the pump.
-  Make sure that your system is installed on a strong and safe base.
-  Always wear eye protection and protective clothing when operating.
-  Hold always the gun with both hands. Do not open the pressure jet without holding firmly the trigger gun.
-  Do not turn the jet against persons, animals and fragile objects.
-  Do not turn the jet against cables or electric equipment, sockets or nearby.
-  Do not place yourself in front of the pressure jet.
-  To clean the delicate surfaces use exclusively fan-shaped jets and keep nozzle 75 cm away.
-  Do not operate gasoline engine in an enclosed area. Be sure that the area is well ventilated.
THE EXHALATION OF THE EXHAUST GAS COULD BE MORTAL!
-  Provide adequate protection in guarding around the moving parts.
-  Do not use the machine to clean surfaces that contain asbestos.
-  Follow strictly the current regulations of draining of the substances taken down from the surfaces where the pressure jet is used.
-  Carry out the preliminary checks recommended by the producer of the machine that incorporates the pump.
-  High pressure jet is dangerous: do not turn the jet against yourself or others.
-  *Pump must not be used by children or not trained personnel.*

Idromeccanica Bertolini S.p.A. declines any civil or criminal liability for damage or accidents to persons or property as may arise from the failure to observe even only one of the above safety rules

2- PRODUCT DESCRIPTION

The LIGHT DUTY Bertolini pistons pumps are exclusively designed for use on spraying equipment; the parts in contact with the liquid are in anodized aluminium and stainless steel. They are compatible for use with chemical products such as pesticides and weed killers in watery solution.

The pumps cannot be used with liquid containing granules or solids in suspension, watery solutions containing sand; Bertolini should not be liable for any damage deriving from improper or incorrect use.

For use with water temperature lower than 4°C or higher than 60°C please consult the *"Bertolini Customer Service"*.

Complete with accessories, these pumps can be easily fitted on sprayers driven by cardan shaft and by electric motors or gas/diesel engines.

The pump must be used in compliance with the specifications indicated on the label (pict. 1); removal of label will avoid all forms of warranty.

Upon receipt of the pump, check over the label which is similar to the one illustrated below.

The following data are indicated on the label:

9. Max. admissible pressure (bar)
10. Max. admissible pressure (P.S.I.)
11. Pump model
12. Flow rate (l/min)
13. Flow rate (G.P.M.)
14. Serial number
15. Required power (KW)
16. R.P.M.

⚠ Do not run the pump over the max. admissible pressure and the max. speed indicated on the label.

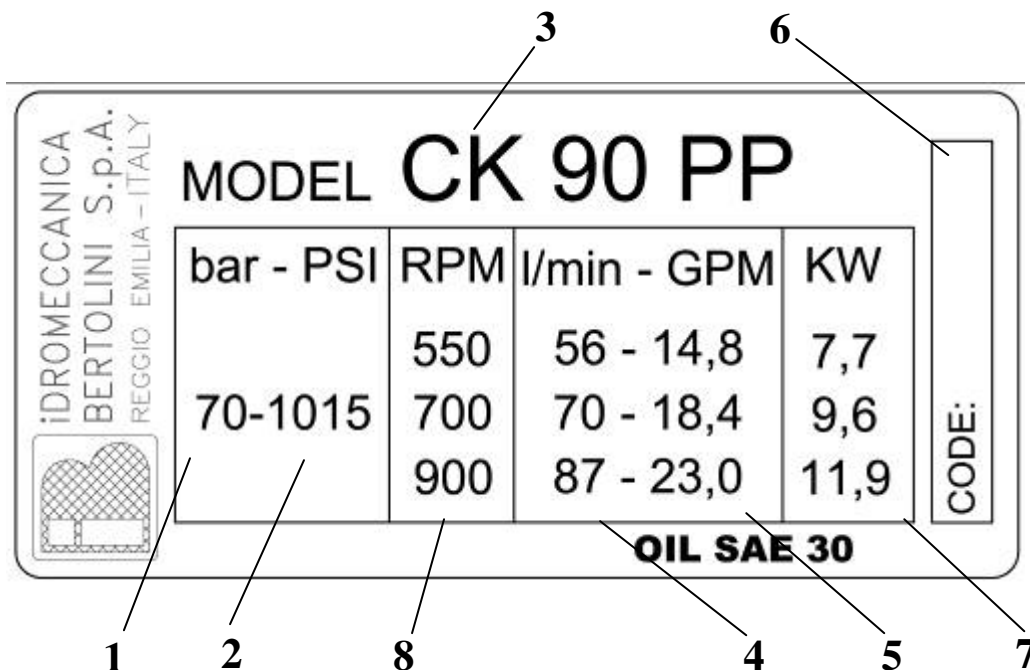

⚠ If the identification label becomes damaged through use, ask your dealer or an authorized Customer Service for replacement.

3- TECHNICAL SPECIFICATIONS

		PUMP SPECIFICATIONS							LIGHT DUTY SERIES					
PUMP		MAX RPM	FLOW RATE at max. pressure		MAX PRESSURE		POWER REQUIRED at max. pressure and flow rate		Shaft Dia. mm	Keyway Dimens. mm	PISTONS			
MODEL	PART NR.		rpm	l/min	GPM	bar	PSI	KW			HP	Nr	Ø mm	
C 40	38.9900.97.3	1450	40	10,5	50	725	4	5,3	24	8x7x25	3	25		
C 53.2 PP	53.6004.97.3	550	50	13,2	50	725	5,4	7,4			10x8x35	3	38	
C 75 PP	53.7001.97.3	550	67	17,7	50	725	6,4	8,6		10x8x55		3	38	
CK 90 PP	73.5105.97.3	900	87	23,0	70	1015	11,9	16			3	45		
CK 115 PP	73.5106.97.3	900	111	29,2	70	1015	15,2	20,4			3	45		
CK 110 PP	73.5102.97.3	550	101	26,6	70	1015	13,8	18,6			3	45		
CK 120 PP	73.5103.97.3	550	111	29,2	70	1015	15,2	20,4			6	45		
CK 180 PP	76.7304.97.3	900	172	45,4	60	870	20,2	27,2			6	45		
CK 230 PP	76.7305.97.3	900	219	57,8	60	870	25,8	34,6			6	45		
CK 220 PP	76.7303.97.3	550	201	53,2	60	870	23,7	31,8			6	45		
C 146 PP	76.7016.97.3	700	180	47,5	70	1015	24,7	33,1			6	45		
C 220 PP	76.7017.97.3	550	208	55,0	50	725	20,4	27,3			6	45		
C 53.2 P	53.6000.97.3	550	50	13,2	50	725	5,4	7,4			1" Spined shaft 3/8	10x8x35	3	38
C 75 P	53.7001.97.3	550	67	17,7	50	725	6,4	8,6					10x8x35	3
CK 110 P	73.5002.97.3	550	101	26,6	70	1015	13,8	18,6	3	45				
CK 120 P	73.5003.97.3	550	111	29,2	70	1015	15,2	20,4	3	45				
CK 146 P	76.7300.97.3	550	141	37,3	60	1015	16,6	22,3	6	45				
CK 220 P	76.7301.97.3	550	202	53,2	60	725	23,7	31,8	6	45				
C 146 P	76.6001.97.3	700	180	47,5	70	1015	24,7	33,1	6	45				
C 220 P	76.7003.97.3	550	208	55,0	50	725	20,4	27,3	6	45				
CA 1024														
CA 1029														

3.2. IDENTIFICATION OF COMPONENTS

3 pistons pump

- 15. Valve caps
- 16. Identifying label
- 17. Oil sight plug with dipstick
- 18. Pump shaft
- 19. Discharge
- 20. Inlet
- 21. Suction valves cover
- 22. Outlet valves cover
- 23. Pump head
- 24. Crankcase
- 25. Mounting rails
- 26. Bearings cover
- 27. Oil drain plug
- 28. Oil level plug

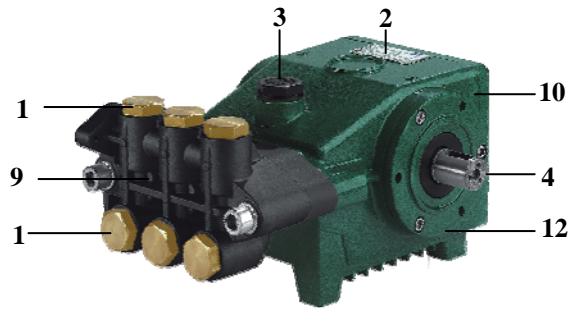

C 40

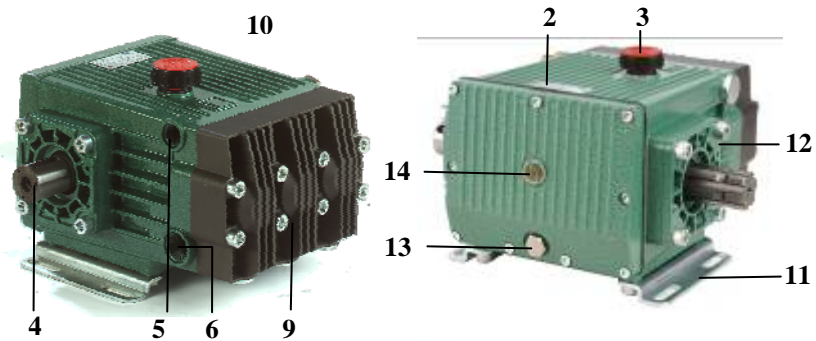

C 53.2

6 pistons pump

The oil drain plug is located on the crankcase opposite side (drive opposite side).



C 75

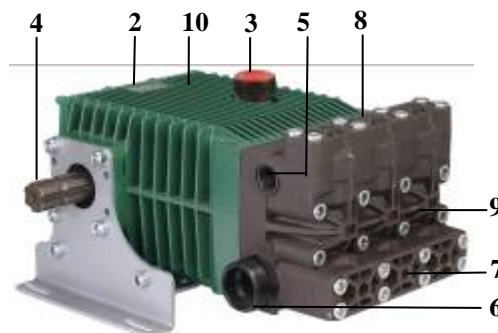

CK 3 PISTONS

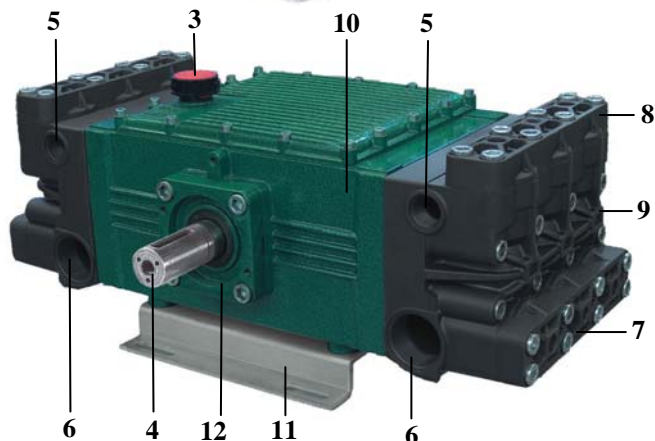

CK 6 PISTONS

3.4 INTENDED USE

- The pump is exclusively designed for use with chemical products such as pesticides and weed killers in watery solution and always compatible with the materials the pump is made. The water temperature must be between +4°C and +60°C.
- The pump cannot be used with:
 - Watery solutions whose viscosity and density exceed those of water.
 - Chemical solutions for which compatibility with the materials the pump is made is unknown.
 - Seawater or water with high concentration of salt.
 - Fuels and lubricants of all kinds and types.
 - Inflammable liquids or liquefied gases.
 - Food-grade liquids.
 - Solvents and diluents of all kinds and types.
 - Paints of all kinds and types.
 - Fluids at temperature lower than 4°C or higher than 60°C.
 - Liquids containing granules or solids in suspension.
- The pump cannot be used for washing persons, animals, electric systems, delicate objects, the pump itself or the system in which the pump is installed.
- The pump cannot be used in places where there are particular conditions, as, for instance, corrosive or explosive atmospheres.

All other use is considered improper.

Idromeccanica Bertolini S.P.A. shall not be liable for any damage deriving from improper or incorrect use.

3.5 FAQ

Question: How much should you reduce the pump R.P.M. in order to get less flow?

Answer: $\text{Required R.P.M.} = \text{Expected flow} \times \frac{\text{Max R.P.M. allowed}}{\text{Max allowed flow}}$

Question: Which diameter the engine/ motor pulley should have to achieve these R.P.M.?

Answer: $\text{External diam. of the engine/ motor pulley} = \frac{\text{External diam. of the pumps pulley} \times \text{pump R.P.M.}}{\text{Engine/motor R.P.M}}$

Question: What's happening if it is not possible to replace the engine/motor pulley?

Answer: $\text{External diameter of the pump pulley} = \frac{\text{External diameter of the motor pulley} \times \text{engine/motor R.P.M}}{\text{Pump R.P.M.}}$

Question: If the engine/ motor is running at lower R.P.M. than the max. R.P.M indicated in the label, which is the maximum flow rate to achieve?

Answer: $\text{Attainable maximum flow} = \text{Engine/motor R.P.M} \times \frac{\text{Max. flow indicated in the label}}{\text{Max. R.P.M. indicated in the label}}$

Max. R.P.M. indicated in the label

Question: What is the approximate power required to achieve the max. performances allowed?

Answer: $\text{Required power (electric motor) (kw)} = \frac{\text{Max flow (L/min)} \times \text{Max pressure (bar)}}{60}$

524

Our customer service is at Your disposal for any further information.

4- INSTALLATION - NORMS

With regard to safety, the Bertolini LIGHT DUTY pumps series meet the UNI EN 809 standards. The pumps version "P" are intended for mounting to PTO of agricultural machines; the pumps version "PP" are intended for direct mounting or by transmission with an electric motor, hydraulic motor or gasoline engine.



The machine or the system where the pump is located must be perfectly built observing the current safety standards in the country where the machine is installed.

For Europe this is guaranteed by the CE mark applied and by the declaration of conformity of the machine in which the pump is installed.

a) In order to assure a correct lubrication of all moving parts, the pump must operate keeping the plungers axle in horizontal position.

b) In particular all the moving parts must be properly protected, in compliance with the current rules, in order to prevent their accidental contact with body parts. If the pump shaft has double PTO, the one that is not used must be protected with a proper shield.



A correct installation is the decisive factor for a good operation and for a long life of the pump. The 90% of problems and malfunctions come from:

- Wrong coupling between pump and engine/motor;
- Wrong coupling between pump and PTO of the agricultural machine
- Wrong inlet circuit;
- Poor quality or incorrect setting of the pressure relief valve or unloader valve.

4.1 USE WITH AGRICULTURAL MACHINES (PUMP "P" SERIES)

In case of pump application to agricultural machines it is necessary to:

- Check that the machine's power take-off does not exceed the max. r.p.m. permitted for the pump.
- When the power take-off is synchronised with the gear, check the manufacturer's manual to identify the gear ratio and the number of motor revolutions corresponding to the permitted r.p.m. of the pump.
- In case of using simple cardanic joints, the two joint angles α_1 and α_2 must be small (less than 45°) and must be as equal as possible (their difference must be lower than 12°) in order not to cause irregular motion.

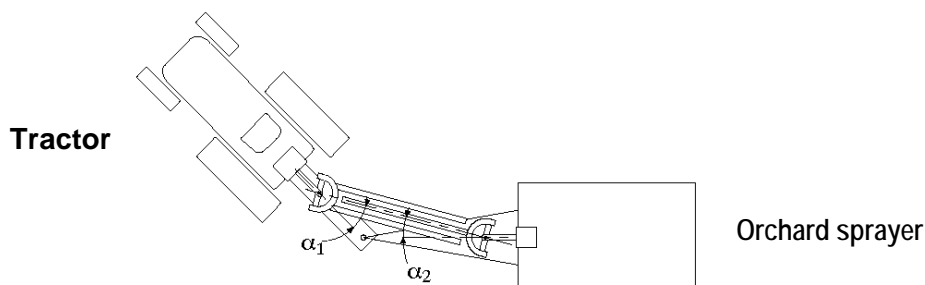

- Using a constant speed universal joint it is possible to work with high angles ($\alpha_1=80^\circ$ max) for short periods. In case the transmission includes a constant speed universal joint on tractor side and a simple cardanic joint on the pump side, we strongly recommend that the simple joint angle does not exceed 16° .

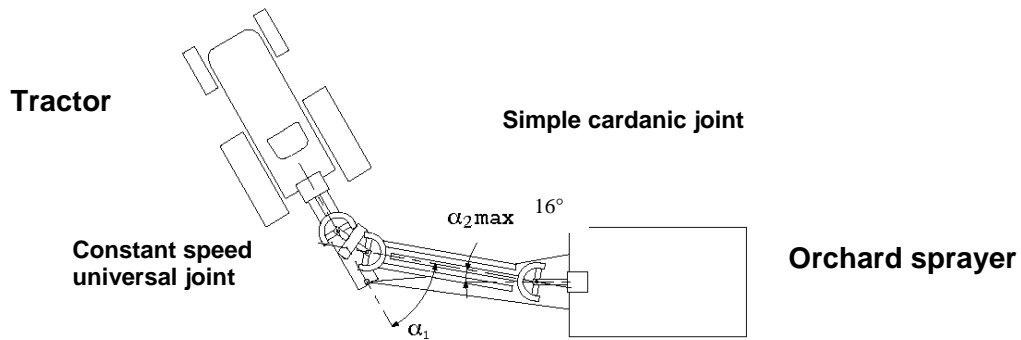

- e) If the pump transmits the motion received from the cardan shaft to other devices (e.g. a fan driven by an overdrive) by a through shaft, the inertial masses involved in the motion can be considerable. Therefore the transmission only accepts very small speed oscillations so as to prevent parts from breaking. In this sort of situation the previous instructions indicated at the above points C and D must be strictly respected.
- f) In case of working with unusual angles or big load it is recommended to fit, between the pump and the cardan shaft, an additional transmission properly sized to relieve the axial thrusts.
- g) The entire cardan shaft, i.e. both the joints and the telescopic shafts, must be kept constantly lubricated, as recommended by the manufacturer.



WARNING!

All rotating parts must be protected. The tractor and pump guards form an integrated system with the cardan shaft guard. Carefully read the manual supplied with the cardan shaft.

Choice of the safety guard to assemble on Bertolini pumps depends on two fundamental factors:

- A) The safety standards UNI EN ISO 4254-1 require the overlap between the pump safety guard and that of the cardan to be “ $S = A - B$ ” ≥ 50 mm;**

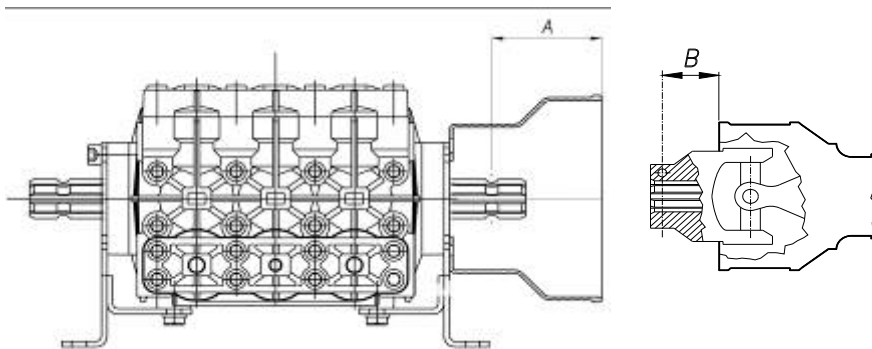

- B) It is essential to be familiar with the specifications of the type of cardan shaft used.**



In the market there are different kinds of cardan shafts with normal and wide angled yokes, torque limiting devices and freely rotating wheels. Since they are not standardised, the projections of their respective guards are extremely variable, so that is difficult to realize which is the correct safety guard to fit on the pump to comply with the required overlap for safety purposes.

The following chart indicates the projection “A” of the safety guard compared to the junction of the cardan on the pump shaft

SAFETY GUARDS PROJECTION "A" (mm)		
PUMPS MODEL	SAFETY GUARD PART NR.	"A" DIMENSION
CK-C 110-120-146-220 P	31.1482.32.2	97,5
C 53.2-75 P	31.1468.32.2	114

To draw the "B" dimension it is necessary to refer to the specific manufacturer's catalogue of the car-dan shaft used.

4.2 USE WITH MOTOR/ENGINE (PUMP "PP" SERIES)

The manufacturer of the complete machine is responsible of the proper selection and correct size of the operation system to prevent possibly bodily injury.



When wiring an electrically driven pump follow all electrical and safety EN 60204.1 standards to prevent accidents.



In particular all moving parts must be properly protected and covered, in compliance with the machines directive 2006/42/CE or with the norms in force in the country the system is used, to prevent bodily injury.



If the pump shaft has a double P.T.O., the one that is not used must be protected with a proper shield.



In case of damage or failure of the shaft protection or of the shaft itself, immediately stop the system and contact a skilled technician.



When using, do not lean hands or feet on the shaft protection.

- The pump-engine/motor unit must be properly fixed on a sufficiently large and strong base.
- All the electric wirings must be carried out by skilled technicians.
- In case of direct drive with the engine/motor make sure that:
 - The motor/engine shaft is perfectly aligned and centred as to the pump shaft.
 - The keyway is of correct length.
 - The coupling is correctly sized.
- In case of gearbox drive follow the same above recommendations as to the coupling between engine/motor shaft – primary shaft and secondary shaft – pump shaft.
- In case of pulleys drives check:
 - There is not any slack between shafts and pulleys.
 - That pulleys are parallel and aligned.
 - That belts are correctly stretched. An excessive belts tension will cause a premature wear of the bearings.

4.3 INLET CIRCUIT

- The inlet circuit must be built-up correctly sized in order to prevent the cavitation phenomenon that occurs when the inlet pressure drops below a specific value. Cavitation damages the pump components. To size-up the inlet circuit refer to the “information on technical installation” of the Master product catalogue. To prevent cavitation it is necessary to limit the suction losses according to the following instructions. In general:
 - The inlet pipelines must be straight as much as possible, reducing curves, elbows and rough fluctuations of section.
 - Do not use oil-pressure pipe fittings, 90° elbows, fittings with multiple ways, wing nuts etc.
 - Do not use foot or one-way valves.
 - Use inlet filter rated at 2.5 times the rated flow of the pump
 - The diameter of the filter pipes must not be smaller than the diameter of the pump inlet pipes.

In any case always check the pressure does not drop below -0,2 bar, using a pressure switch/pressure gauge installed in the suction pipe fitting of the pump.

Furthermore make sure that:

- **The inlet pressure of the pump should never exceed 5 bar.**
- **Filter** with a filtering degree between 50 and 80 mesh must be installed. The presence of the filter leads to suction loss that reduces the height from which the pump can suck. That is why it is important to fit a filter of sized nominal flow rate in order to ensure that this phenomenon is not too excessive. We recommend to fit a filter rated at least 2.5 times the rated flow of the pump.
- The filter must be installed as close as possible to the pump in an easily accessible position, and must be inspected before each pump starting.
- In case of inlet in pressure through a centrifugal pump, make sure the provided flow rate is at least 1.5 times more than the pump flow rate.
- The tank must be rated at least 4 times the rated flow of the pump.
- The pump inlet pipes must be located close to the tank bottom, water head of at least 200 mm, to prevent the formations of siphons.
- The suction area must be protected from turbulence created by the inlet pipe of the tank, and from the return pipelines, through special bulkheads closed on the bottom.
- We suggest to carry out the part of pipeline directly next to the pump with flexible hoses, suitable to isolate the rest of the system from the vibrations caused by the pump-engine/motor unit.
- Only use stiff or flexible anti-crushing hoses.
- Do not install devices for detergent sucking in the inlet circuit of the pump.
- The inlet line, before being connected to the pump, should be perfectly clean inside.

In case of application with electric motors the system must be provided with sensors to protect the pump from the problems resulting from possible water overheating or poor suction.

- Install **a thermostat** inside the tank indicating too high temperature and a **level control device** indicating lack of water in the tank; in case of release, these sensors stop the motor.
- Next to the inlet circuit install a **Pressure switch**, able to stop the engine/motor when the inlet pressure decreases below the value of incipient cavitation.

4.4 HIGH-PRESSURE CIRCUIT

- ⚠ All the parts of the high-pressure circuit must be sized for minimum performances, (pressure and flow) at least 30% more than the pump performances.
- ⚠ it is necessary to fit a **pressure regulating valve** set at the working pressure. This valve permits the excessive fluid to flow back in the tank, preventing that dangerous pressures arise. It is quite normal that the pump flow is “oversized” than the actual need. For correct running of the system, the water recycled through the regulating valve should not exceed 10-15% of the pump flow. Otherwise, besides the useless energy waste, water overheating will be generated in the suction tank, thus increasing the cavitation risks.
- ⚠ **For your and for the system safety it is necessary to fit on this circuit a safety valve set at a pressure of 15-25% more than the setting value of the regulating valve. The safety valve and the regulating valve must carryover the stamping of the name of the manufacturer and the max. rated pressure, the max admissible flow and temperature.**
- ⚠ In case the safety valve frequently releases, immediately stop the pump and check the system with the help of a skilled technician.
 - Do not connect the safety valve by-pass and the regulating valve by-pass to the inlet line.
 - Especially using an automatic regulating valve we recommended to fit, immediately after the pump, a properly sized pulsation damper.
- ⚠ It is important to fit a **pulsation damper** precharged at 50-60% of the pump working pressure, able to damp the vibrations of the whole hydraulic system. It must be sized according to the pump performances and to the instructions provided by the manufacturer. On the body the following information must be stamped: manufacturer brand, max pressure allowed, test pressure, pre-charge pressure, capacity and manufacturing date. When tests are foreseen, the serial number and the test initials required in the country where the machine is installed must appear as well.
 - We recommend to install in the first part of piping flexible hoses, able to isolate the rest of the system from the vibrations caused by the pump-engine/motor unit.
- ⚠ **The flexible hoses** must be mechanically seamed by the manufacturer, and the following information must be stamped: the name of the manufacturer, the manufacturing date, the rated pressure and the maximum admissible temperature.
 - Use pressure gauges in glycerine bath able to stand pulsating pressures.
 - The discharge line must be provided with a low pressure by-pass device to evacuate rapidly the air in the pump head and to facilitate priming.

The high pressure circuit is subject to pressure losses caused by its structure; therefore it is normal that the working pressure is lower than the pressure of the pump head.

4.5 INSTALLATION DIAGRAM

TYPICAL INSTALLATION OF A 3 PISTONS PUMP FOR AGRICULTURAL APPLICATION

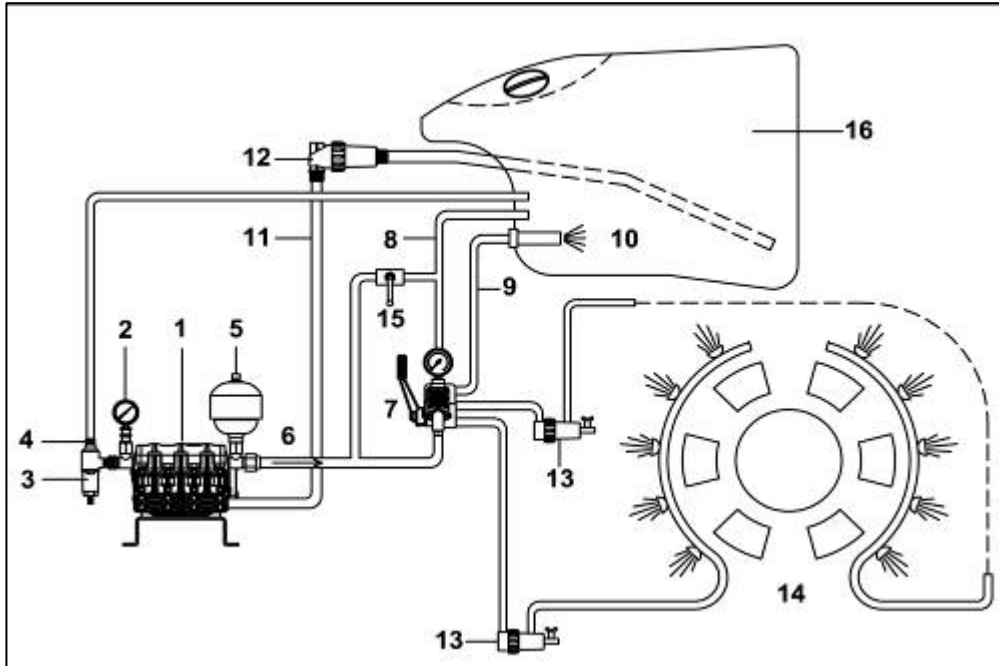

- | REFERENCES | |
|------------|--|
| 1. | Pump. |
| 2. | Pressure gauge. |
| 3. | Safety valve |
| 4. | Safety valve by-pass |
| 5. | Pulsation dampener. |
| 6. | Discharge line. |
| 7. | Pressure regulating valve. |
| 8. | Pressure regulating unit by-pass. |
| 9. | Outlet for agitation. |
| 10. | Agitators. |
| 11. | Inlet line. |
| 12. | Suction filter. |
| 13. | On line filters. |
| 14. | Nozzles |
| 15. | Tap to set to zero pressure when starting the pump |
| 16. | Tank. |
| 17. | Inlet manifold |
| 18. | Outlet manifold |

TYPICAL INSTALLATION OF A 6 PISTONS PUMP FOR AGRICULTURAL APPLICATION

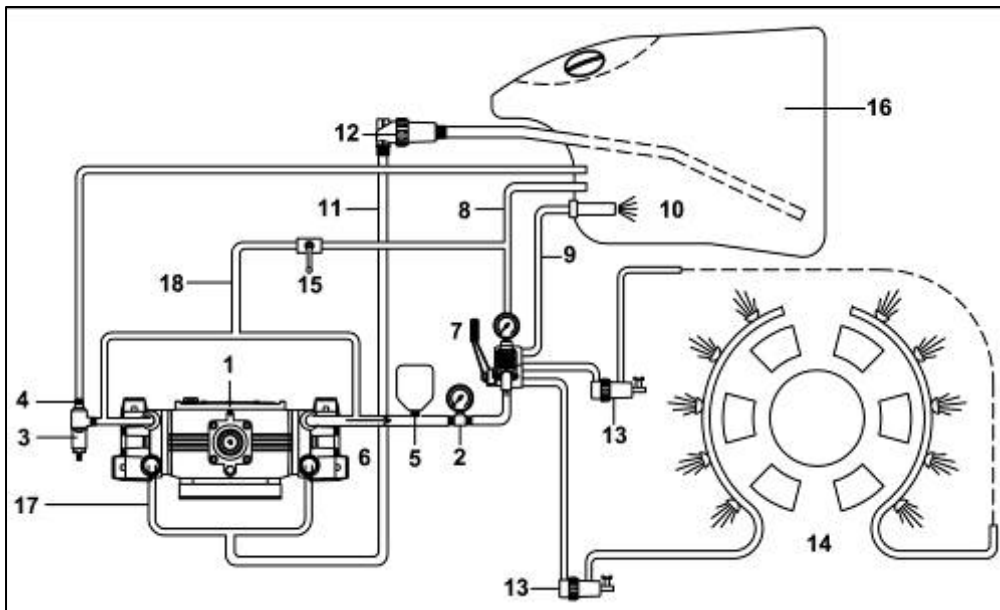

All the six piston pumps series C-CK feature an internal connection of outlets with clear passage of 14mm.

TYPICAL INSTALLATION OF A 3 PISTONS PUMP FOR INDUSTRIAL APPLICATION

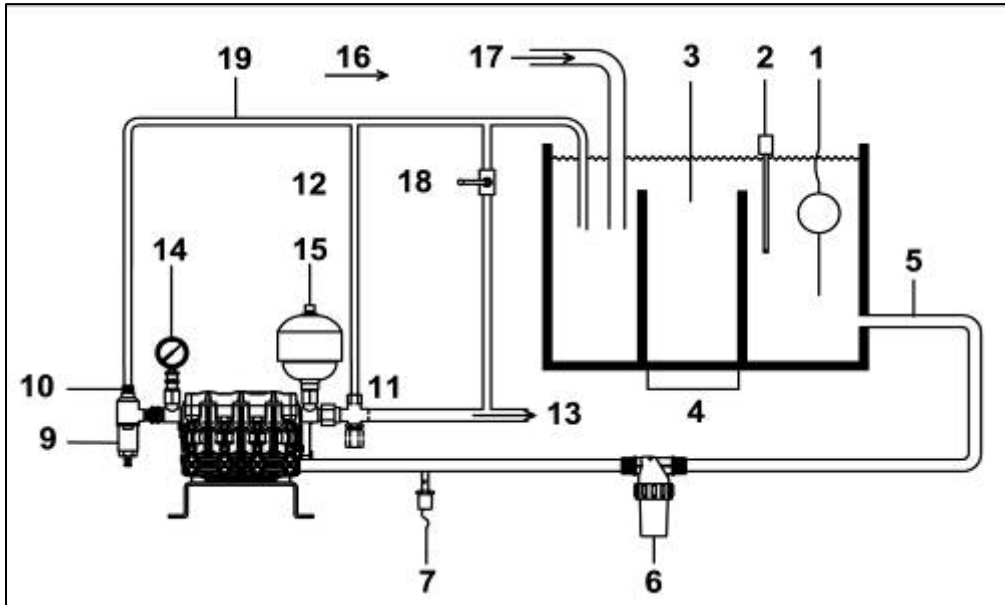

REFERENCES

- Level control device.
- 2. Thermostat.
- 3. Minimum tank capacity=pump flow rateX4.
- 4. Watertight bulkheads closed on the bottom
- 5. Inlet line
- 6. Suction filter
- 7. Inlet pressure switch
- 8. Inlet manifold (minimum admissible passage dia. 33mm)
- 9. Safety valve
- 10. Safety valve by-pass
- 11. Pressure regulating valve
- 12. Pressure regulating valve by-pass
- 13. Discharge line
- 14. Pressure gauge
- 15. Pulsation dampener.
- 16. By-pass line.
- 17. Supply line.
- 18. Tap to set to zero pressure when starting the pump
- 19. Minimum admissible passage dia. 25
- 20. Minimum admissible passage dia. 18

TYPICAL INSTALLATION OF A 6 PISTONS PUMP FOR INDUSTRIAL APPLICATION

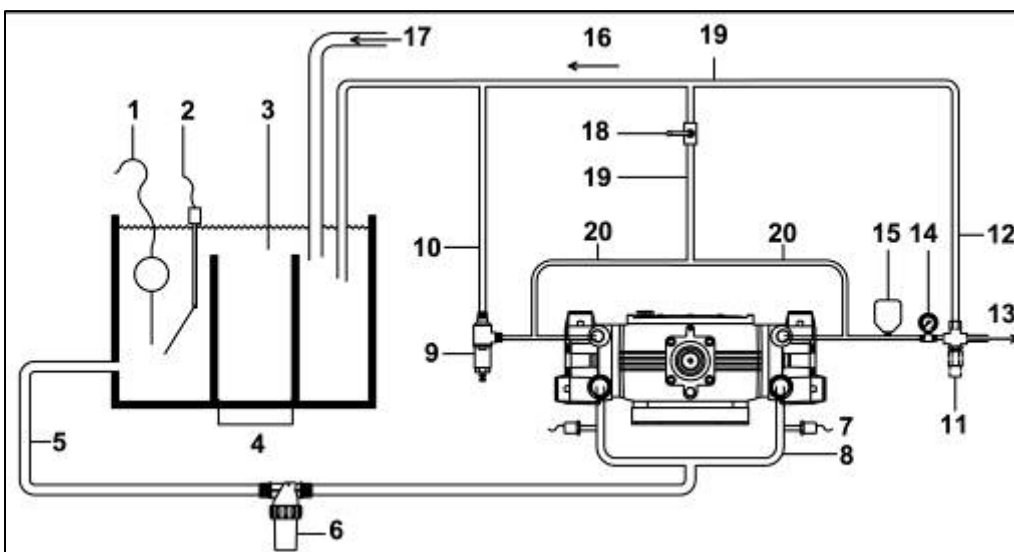

All the six piston pumps series C-CK feature an internal connection of outlets with clear passage of 14mm.

5- SETTING UP

Preliminary checks: before starting the pump, make sure that:

- The inlet line is connected and sealed.
- The filter is clean.
- All the seizure valves on the inlet line are open and water normally flows to the pump. **Do not run the pump dry.**
- All the outline lines are connected to the nozzles.
- The coupling allowances between the pump shaft and the driving parts (joints misalignment, cardan inclinations, shaft-pulley gap, belts stretching, etc.) remain into the limitations foreseen by the transmission manufacturer.
- Replace the oil plug without vent (red colour) by the oil plug with dipstick. This operation could have already been carried out by the producer of the machine where the pump is installed.
- When pump is not working, check that the oil level is halfway up to the sight glass. The oil level can be also checked by unscrewing the vent plug: the correct level is indicated between the high and low marks on the dipstick. The correct oil level must be always checked when pump is not working and is completely cooled down.
- Before starting the pump, carefully read the instruction of this manual and the use and maintenance manual of the machine incorporating the pump.
- Make sure that all moving parts are adequately protected and covered and that they cannot be accessed by unauthorised personnel. For applications with cardan shaft refer to chapter 4.1, for application with electric motors or engines refer to chapter 4.2.
- If freezing conditions are likely to be met check the possible presence of ice inside the pump.
- Carry out the preliminary checks prescribed by the producer of the machine incorporating the pump.

CAUTION

- **The pump can be set at work only if the machine in which it is installed it conforms the safety standards established by the European Directives. This fact is guaranteed by the CE mark applied and by the Declaration of Conformity provided by the manufacturer of the machine in which the pump is installed.**
- Don't use the pump:
 - If it has been subjected to strong impact;
 - If there are visible oil leaks;
 - If there are visible water leaks.

In these cases have the pump be checked by a **skilled Technician**.

- **Have a skilled Technician** makes the scheduled checks as per the extraordinary maintenance.

5.1 Starting procedure

- Start the pump without any pressure, after setting to zero the pressure regulator or opening the possible by-pass devices.
- Check the RPM do not exceed the max. value indicated in the label.
- Before taking the pressure to the required value, wait until all the air in the circuit has come out and the water comes out with a continuous and firm jet.

⚠ During the winter months, and in case of intense cold, before starting the pump, check the possible presence of ice in the inlet and in the pressure circuits.
Do not run the pump before the circuit has been completely defrosted.

5.2 Operation



Caution! The high pressure jet, if incorrectly used, may damage persons, objects and animals. **No operation must be carried out when the system is working**, except the pressure regulation. If, for instance, it is necessary to tighten a plug, or a fitting, to control a high-pressure hose, or other, **before carrying out the operation, reset the pressure and stop the pump.**

- The water jet must be always directed to the operating area, even during tests and preliminary controls.
- Do not run the pump before having directed the jet towards the operating area.
- The operating area concerned with the jet must be forbidden and cleared of objects which, if bumped by the pressure jet, can be damaged or blow away.
- Check the trajectory of the fragments removed by the water jet and, if necessary, use proper bulkheads to protect anything could be accidentally struck by the fragments.
- Too high pressures may damage the objects that you require to wash; we recommend carrying out preliminary operating tests (working pressure, distance from the nozzle, from the object, etc.).

Idromeccanica Bertolini S.p.A. declines any civil or criminal liability, for damage or accidents to persons or objects, as may arise from the improper use of the pump and other relevant accessories in the system where the pump is installed.

5.3 Water leaks from seals

- In some pumps, when starting up you can notice a little leak of water (a few drops), from the area under the crankcase: it is a normal factor for the correct pump operation.

5.4 Pump Shutdown

- Stop the pump only after setting to zero the pressure operating on the pressure regulator or on the by-pass devices.
- If chemical products have been used, run the pump with clean water for a few minutes. Then, empty the pump, disconnecting the suction and running the pump for about 20 seconds.
- During the winter months, when the pump is subject to freezing conditions, or when you foresee a long time of no operation, it is necessary to empty all the circuit from the fluid residues, or mix clean water with anti-freeze liquid in correct proportions.

6- TROUBLESHOOTING

FAULT	PROBABLE CAUSE	CURES
When starting, the pump does not supply water and does not make any noise	Shortage of water in the inlet circuit Blocked valves The outlet line is closed and does not allow the air in the head to come out	Check the circuit and water level in the tank. Check and replace if necessary. Drain the outlet line until the water regularly comes out
The pump is noisy and beats improperly	Pump is sucking air The Inlet plumbing is incorrectly sized Jammed or worn valves Worn high pressure seals Malfunctioning of the pressure regulator Problems with driving The number of revolutions is higher than the value indicated on the label	Check suction circuit and possible air ingress Check the correct size of the suction circuit. Check the filter cleaning Check and, if necessary, replace Check alignment, gaps and settings. Restore the proper number of revolutions
Vibrations or strokes on the pipeline	Air intake Malfunctioning of the pressure regulator The pressure regulator by-pass line is undersized or throttled. Jammed valves	Check the suction circuit and possible air ingress Check and if necessary replace. Check the correct sizes and remove throttlings Check and/or replace if necessary.
The pump normally runs, but does not achieve the required performance	The Inlet plumbing is incorrectly sized Malfunctioning or not correctly adjusted pressure regulator Nozzle of wrong size or worn Worn plunger seals Worn check valves The number of revolutions is lower than the value indicated on the label	Check the correct size of the suction circuit. Check the filter cleaning. Check and/or replace if necessary. Restore the proper number of revolutions.
The pump is noisy and gets overheated	Excessive temperature of water The working pressure is higher than the one indicated in the label The number of revolutions is higher than the value indicated on the label Excessive stretching of the belts Oil not at the correct level, contaminated or exhausted Worn bearings	Reduce the water temperature. Restore the proper values. Check, fill or change if necessary. Replace.
Water dripping below the pump	Worn Packings Worn plunger O-Ring retainer	Check and/or replace Check and/or replace
Oil dripping	Worn plunger oil seal	Check and/or replace

The pressure gauge shows irregular oscillations at high pressure with open lance	Valve with impurities	Clean the valve and lubricate the parts with grease.
	Worn Plunger seal	Check and/or replace
	Worn Check valves	Check and/or replace

CAUTION!: nozzle is subject to wear, to be replaced every time your pump will not reach the required pressure; in fact, when worn, its hole is becoming larger, so the actual flow rate increases and pressure decreases.

7- WARRANTY

The liability of the manufacturer under the period of warranty (12 months from date of manufacturer's shipment) is limited to the replacement of the parts that, upon examination, appear in Bertolini's satisfaction to have been defective in material or workmanship.

This warranty is valid only when the fault is ascertained by its technicians, it shall not apply to any pump which have been repaired or altered to adversely affect the performance or reliability of the pump.

This warranty does not apply to malfunctions caused by fault or negligence of the buyer or third party, to the improper use of the pump, to failures reported to the manufacturer after the warranty period has expired, or to the normal wear of the component parts of the products such as seals, cups, O-Rings, valves, etc.

Costs of labour, packages and transport costs are at the Buyer's charges . Products, after receipt pf written factory approval, must be returned complete with all parts and not tampered. Otherwise warranty is void.

This warranty is subject to the following conditions:

- *Pump must be used within the specifications indicated in this manual and in the manual of the machine where the pump is installed. A safety valve must be correctly installed in the system.*
- *The warranty is void if pump is operating without sufficient fluid to the pump (cavitation).*
- *The warranty is void if pump is operating without oil in the crankcase.*
- *Protect pump from freezing. Do not store in area with freezing conditions. Drain completely of pumped fluid. Flush with antifreeze. Do not store or operate in excessively high temperature areas or without proper ventilation.*
- *The warranty is void if installation is not correct.*
- *The warranty is void if the recommended maintenance instructions are not observed.*
- *Different uses of the pump than the ones mentioned in the paragraph "Intended Use".*
- *The warranty is void if the pump use does not conform to the specific current safety standards and if the machine incorporating the pump is without CE marking.*
- *Use of non-original spare parts or even not suited for the pump model.*

USE OF OTHER THAN BERTOLINI PARTS VOIDS THE WARRANTY

ANY PRODUCT MUST BE RETURNED FREE BERTOLINI FACTORY PARTS RETURNED MUST HAVE FACTORY APPROVAL DOCUMENTATION PRIOR TO RETURN.

8- ROUTINE SERVICE AND REPAIR

8.1 Crank gear and lubrication

- Check at least once a week the oil level using the proper dipstick.
- After 50-100 hours of operation it is necessary to change the oil with a regular transmission oil **SAE 30, enriched by the specific additive supplied by Idromeccanica Bertolini**. As to the additive percentage refer to the instructions included in the package. This change assures an efficient lubrication for the rest of that pump's life.
- If the pump is used in humid climates or environments, the water in the air normally tends to condense and to mix with the pump oil, which takes on a typical whitish colour. In this case it is necessary to check the oil more frequently, and if water was found immediately change it.
- When water is in the oil immediately check the origin and replace respective seals. Before changing oil, accurately wash crankcase, shaft, bearings and connecting rods.

CAUTION: Operating pump with emulsified oil (with water, condensation etc.), reduces the lubrication of the moving parts, and will result in overheating and premature failures.



Protect the environment from liquids contained in the pump.
Collect the residues and dispose of them regularly; no residue must get into the piping system or into the ground.

8.2 Check Valves

Pump C53.2

Disassembly

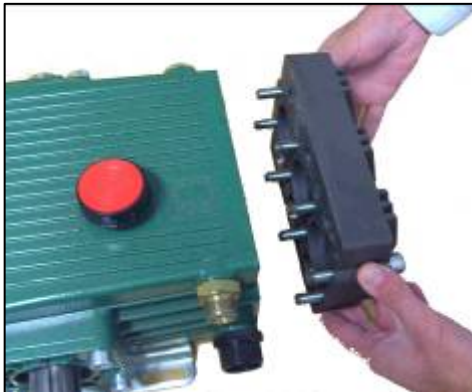

Picture 1



Picture 2

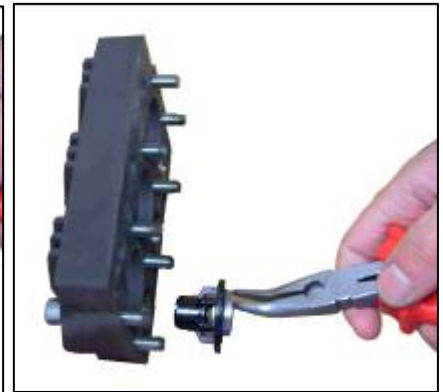

Picture 3

Access the check valve assemblies removing the pump head by the 8 M10 Allen screws (picture 1).

4. Take out the discharge valves and the relevant O-Rings from their seat in the crankcase, using a pair of pliers (picture 2).
5. Take out the suction valves and the relevant O-Rings from their seat in the head, using a pair of pliers (picture 3).
6. Check the housings bottom, on the head and on the crankcase, it must be absolutely smooth and with no flutings or wear marks.

Checks

1. Check the O-Rings integrity
2. Check the valve springs integrity.
3. Check the poppets are not stuck to their seat and they freely run within the plastic cages.
4. Check the integrity of the cages and particularly verify they are not deformed or damaged by wear.
5. Check the seat-poppet areas do not show pitting or wear marks.

Assembly

5. Insert the valves in their housings
6. Lubricate the O-Rings with a coat of oil and locate them in the valve seats.
7. Check the integrity of the O-Rings on the front gland and replace them if they are worn
8. Fit the pump head, and tighten the 8 screws M10 to 40 Nm torque.

For other models

Disassembly



Picture 4



Picture 5



Picture 6

Access the check valve assemblies by removing the valve caps for the pump C40 (picture 4) and the valves covers for the other pumps (picture 5).

1. Take out the valves and the relevant O-Rings from their seats on the head using a pair of pliers (picture 6).
2. Check the housings bottom, on the head and on the crankcase, it must be absolutely smooth and with no flutings or wear marks.

Checks

1. Check the O-Rings integrity
2. Check the valve springs integrity.
3. Check the poppets are not stuck to their seat and they freely run within the plastic cages.
4. Check the integrity of the cages and particularly verify they are not deformed or damaged by wear.
5. Check the seat-poppet areas do not show pitting or wear marks.

Assembly

If worn, the valves must be replaced; the kits parts numbers are indicated on the breakdown sheets attached to each pump.

1. Lubricate the O-Rings with a coat of oil and locate them in the bottom housing

2. Insert the valves in their housings; be careful that the valve position is perpendicular to the bottom of its housing.
3. Reassemble the valve caps for the pump C40 and the valves covers for the other pumps models.

For the pump C40 tighten the valve caps to 70Nm torque.

For the other pumps tighten the valves covers screws to:

40 Nm torque (screws M10 for PUMPS C53.2-C75)

70 Nm torque (screws M12 for PUMPS CK SERIES)

110 Nm torque (screws M14 for PUMPS C SERIES)

8.3 Packing/Seals



Picture 7



Picture 8



Picture 9

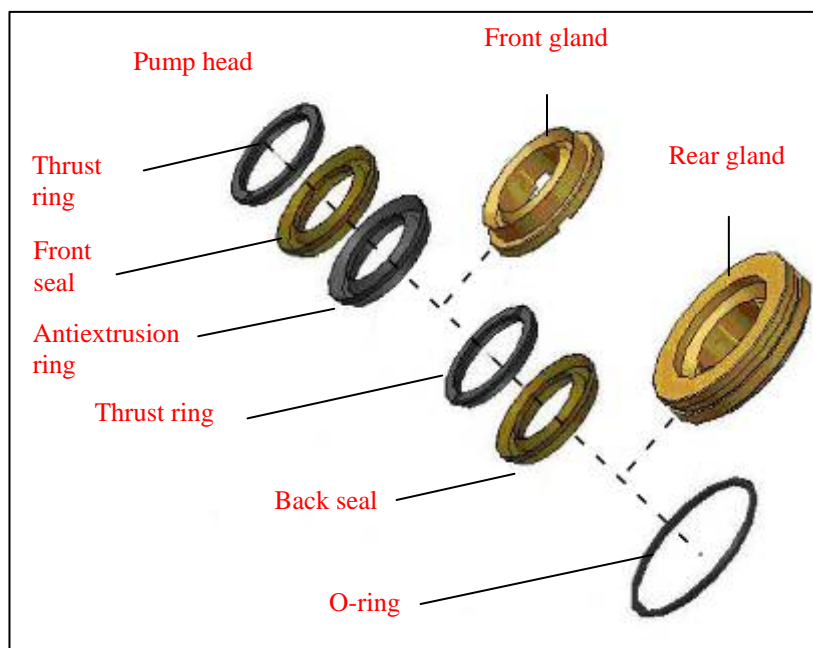

Picture 10

Disassembly

1. Using a 8mm Allen wrench (PUMP C53.2); 10mm Allen wrench (PUMPS C40-C75-C-CK series) remove the head bolts then take out the head using a plastic hammer (pictures 7 and 8)
2. Extract the packing assemblies using a proper packing extractor reported (see chart page 25)

picture 9).

If you do not have a packing extractor you can use expansion pliers.

Assembly

5. Clean and lubricate the glands.
6. Install the new seal in the head housing previously lubricated, taking care not to damage the external lip of the seal.
7. Replace the seals or the complete packing assemblies as needed; consider that the brass glands must be replaced only in case of visible wear marks. The picture 10 shows a generic packing assembly; the components are not the same for all series, follow the parts list and the breakdown supplied with each pump.
8. Lubricate the plungers with waterproof grease. Reassemble the head focusing on the plungers using a plastic hammer. Tighten the screws:
 - o M10 to 40Nm torque for PUMPS C53.2,
 - o M12 to 70Nm torque for PUMPS C40-C75-C-CK.

8.4 plungers oil seals

This operation should be carried once the pump has been dismantled, but to easily take out the oil seals use a screwdriver with a sharp and shaped end as indicated below (picture 11).



Picture 11

Rotate the pump shaft until the plunger corresponding to the oil seal to service is at the bottom dead center (B.D.C.) (picture 12).

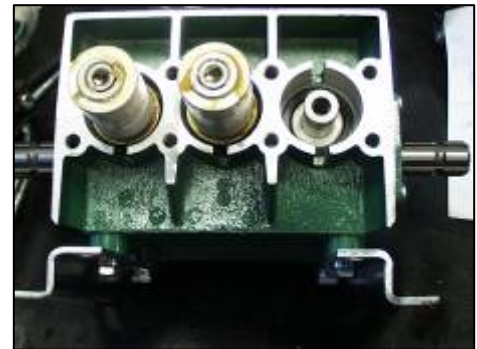

Picture 12

Using a screwdriver with a sharp end (picture 11) and a hammer, punch the metal structure of the oil seal (picture 13).

Rotate the screwdriver by 90° so that the pawl is secured on the oil seal, then push up.

Fit the new oil seal after lubricating with oil or grease both the internal and external edges.

Push it on its housing using the proper tool (see chart page 25)



Picture 13

8.5 Shaft oil seals

Disassembly:

STEP 1:

Using a hammer, insert a flat edge screwdriver into the metal structure of the oil seal (picture 14).

STEP 2:

Take out the oil seal as indicated in the picture 15



Picture 14



Picture 15

Reassembly:

Insert the new oil seal into the proper tool (picture 16) and install it on its housing, using a hammer (picture 17).

For the pumps C.53.2 and C75 it is necessary to remove the bearing cover before taking out the oil seals. After replacement fit the cover and tighten the M10 screws to 40Nm torque



Picture 16

Caution: don't try to install the oil seal without using the proper tool (see Repair Tools chart), because the grooves or the keyway on the shaft would surely damage the sealing edge.



Picture 17

8.6 Repair tools chart

Function	Pump model	Part number
Extractors to remove the packing assemblies	C.40 (D.25)	31.8759.97.3
	C 53.2 (D.38)	77.1382.97.3
	C 75 (D.38)	77.1495.97.3
	C-CK (D.45)	77.1178.97.3
Special tools to install the oil seals of the plunger rods	C.40	78.3171
	C 53.2 / C 75	77.1540 77.154/A
	CK 110 – CK 120	77.2331 77.2332
	C 146 – C 220	77.2331/A
	CK 180-220-230-146	77.2331/A
Special tools to install the oil seals on the shaft	C40	77.3396
	C 53.2 / C75	77.2330
	CK 110 – CK 120	77.2804
	C 146 – C 220	77.2337
	CK 180-220-230-146	77.2337

All tools to service the pumps can be supplied directly, on request, by Idromeccanica Bertolini.

9- MANUFACTURER'S DECLARATION

Manufacturer's Declaration

Machines Directive 2006/42/CE (Attachment II point B)

Idromeccanica Bertolini S.p.A. declares under its sole responsibility that the pumps series:

LIGHT DUTY

with the serial number: _____

(to be filled in by purchaser according to identification label)

- is manufactured to be incorporated in a machine or to be assembled in with other equipments to form a machine required by Directive 2006/42/CE

- the producer of the machine that incorporates the pump is the only responsible of the accordance in every points to this Directive's standards.

Therefore Idromeccanica Bertolini S.p.A. declares that the above pumps must not be put into operation up to the machine in which it will be built-in will be identified and will be declared in compliance with the Directive's standards 2006/42/CE.

Reggio Emilia 01.06.2011

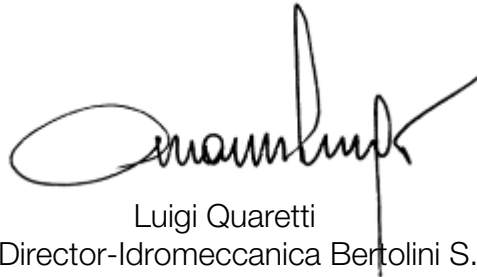

Luigi Quaretti
(Managing Director-Idromeccanica Bertolini S.p.A.)

PART. NR. 31.1647.99.2 REV 00