

PISTON PUMPS

Series C300

**IDROMECCANICA
BERTOLINI**

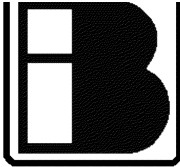

**Operating,
Set -up,
Service and
Safety
Instructions
Manual**

**CK 3003
CA 316
CPQ
CK 3006
pumps**

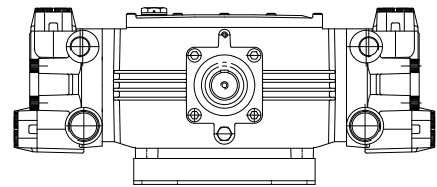
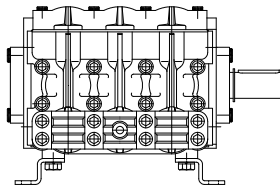
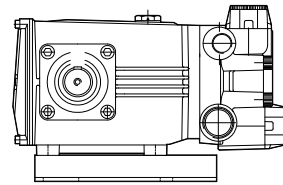
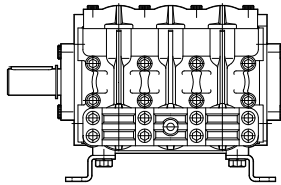

GB



**IDROMECCANICA
BERTOLINI**

Reggio Emilia - Italy

Via F.lli Cervi 35/1 42124 REGGIO EMILIA - ITALIA

MANUFACTURER INFORMATION:

Manufacturer: IDROMECCANICA BERTOLINI S.p.A.
Via F.lli Cervi 35/1
42100 REGGIO EMILIA - ITALIA
Tel. +39 0522 306641 Fax +39 0522 306648
E-mail: email@bertolinipumps.com
Internet: www.bertolinipumps.com

Issued: June 2005
Update: 02 December 2013

You have decided to show your preference for “**BERTOLINI**” and have bought a product built with the most modern technology and the finest materials, famous for their quality, duration and functionality.

We thank you for the trust shown in our products.

Please read and always keep with you this handbook: it will be useful for any information needed on the features and functionalities of the product.

Thank you for choosing “Bertolini”

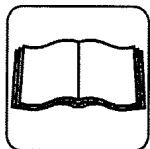

Idromeccanica Bertolini S.p.A. recommends a careful reading of the present Use and Maintenance Handbook, before installing and using the pump. Should you keep it within easy reach for any further reference. The Handbook has to be considered as an integral part of the pump itself.

The user of the pump and the responsible of the installation are expected to observe and comply with the relevant legislative provisions currently in force in the country where the pump is to be used. They are also required to carefully follow the instructions set out in the present Handbook.



















TABLE OF CONTENTS

This Use and Maintenance Handbook is composed by the following chapters:

1. GENERAL SAFETY REGUALTION	Page 4
2. PRODUCT DESCRIPTION	Page 5
3. TECHNICAL SPECIFICATION	Page 6
3.1 Identification of Components	Page 7
3.2 Aim of Use	Page 8
4. INSTALLATION – NORMS	Page 9
4.1 Pump Engine/Motor Coupling	Page 9
4.2 Inlet Circuit	Page 10
4.3 High Pressure Circuit	Page 10
4.4 Typical installation scheme	Page 12
4.5 Errors to avoid	Page 13
5. SAFETY DEVICES AND MALFUNCTIONING PREVENTION	Page 14
5.1 Safety Devices	Page 14
5.2 Malfunctioning Prevention	Page 14
5.2A Overpressures protection	Page 14
5.2B Protection from abrasive particles	Page 14
5.2C Protection from pulsations	Page 15
5.2D Protection from cavitation and inlet circuit calculation	Page 15
5.2E Protection from overheating	Page 18
5.2F Protection from starving	Page 18
5.2G Energy saving/pump correct use	Page 18
6. FAQ	Page 19
7. SETTING UP	Page 20
7.1 Starting Procedure	Page 21
7.2 Operation	Page 21
7.3 Water leaks from seals	Page 21
7.4 Pump Shut Down	Page 21
8. Troubleshooting	Page 22
9. Warranty	Page 23
10. ROUTINE MAINTENANCE	Page 24
10.1 Crank gear Maintenance and Lubrication.	Page 24
10.2 Check Valves Service	Page 25
10.3 Packing/Seal Service	Page 26
10.4 Plungers oil Seals Service	Page 27
10.5 Shaft oil seals Service	Page 28
10.6 Repair tools chart	Page 29
11. MANUFACTURER'S DECLARATION	Page 30

- a) This handbook complies with the technical knowledge applicable at the date of the sale of the product and shall not be considered inadequate for the sole reason it has been subsequently updated according to new experiences. **IDROMECCANICA BERTOLINI** has the right to up-date its products and related handbooks without being obliged to up-date previous products and handbooks, except in cases exclusively required by safety reasons.
- b) The **“Bertolini Customer Service”** is available for any need arising when using or maintaining the product, and for choosing related accessories.
- c) No part of this handbook can be reproduced without the written permission of **IDROMECCANICA BERTOLINI S.p.A.**

1- GENERAL SAFETY RULES

-  The high energy of the pressure jet is a source of serious dangers.
-  Only skilled personnel must use the pump.
-  It is recommended to fit mechanically pre-fastened high-pressure pipes. They must be homologated for the Max. admissible pressure in the system, and they must carry over the stamping of the overpressure and the Max. admissible temperature, besides the name of the manufacturer and the date of production.
-  Before starting, always check your system.
-  Particularly check the pipeline integrity, the high-pressure fittings and the gun trigger, which should work in a soft way, without releases, and should immediately return to its position, when released.
-  Do not use defective high-pressure pipe and do not try to repair it, rather replace it by an original spare part.
-  Keep children and animals away when the system is working.
-  The system must be installed on a strong and safe base.
-  Always wear eye protection when operating.
-  Always hold the spray gun with both hands when using.
-  Do not turn the jet against people, animals and fragile objects.
-  Do not turn the jet against cables or electric equipment, on sockets and nearby.
-  Do not place yourself in front of the pressure jet.
-  To clean delicate surfaces exclusively use fan-shaped jets and keep nozzle at least 75 cm away.
-  If the system operates with gasoline engine, be sure the installation area is adequately ventilated.
- THE EXHALATION OF THE EXHAUST GAS COULD BE MORTAL!!!
-  All the moving parts, and in particular the drive function units, must be well protected against accidental contacts.
-  Do not use the equipment to clean surfaces containing asbestos.
-  Strictly follow the current regulations related to the draining of substances taken down from the surfaces where the pressure jet is used.

Idromeccanica Bertolini declines any civil or criminal liability for damage or accidents to persons or property arising from the failure to observe even only one of the above mentioned safety regulations.

2- PRODUCT DESCRIPTION

Bertolini high-pressure piston pumps are designed to be used with clean water, with a temperature of up to 60°C.

If you pump corrosive additives with higher temperature please consult the “Bertolini Technical Service”.

The pump operation must comply with the specifications indicated on the label (fig. 1); removing the label implies the loss of any warranty.

Upon receipt of the pump, check the label is similar to the one illustrated below.

The following data are indicated on the label:

1. Max. admissible pressure (bar)
2. Max. admissible pressure (P.S.I.)
3. Pump model
4. Flow rate (l/min)
5. Flow rate (G.P.M.)
6. Serial number
7. Required power (KW)
8. Speed

⚠ The Max. admissible pressure and the Max. speed indicated on the label cannot be exceeded.

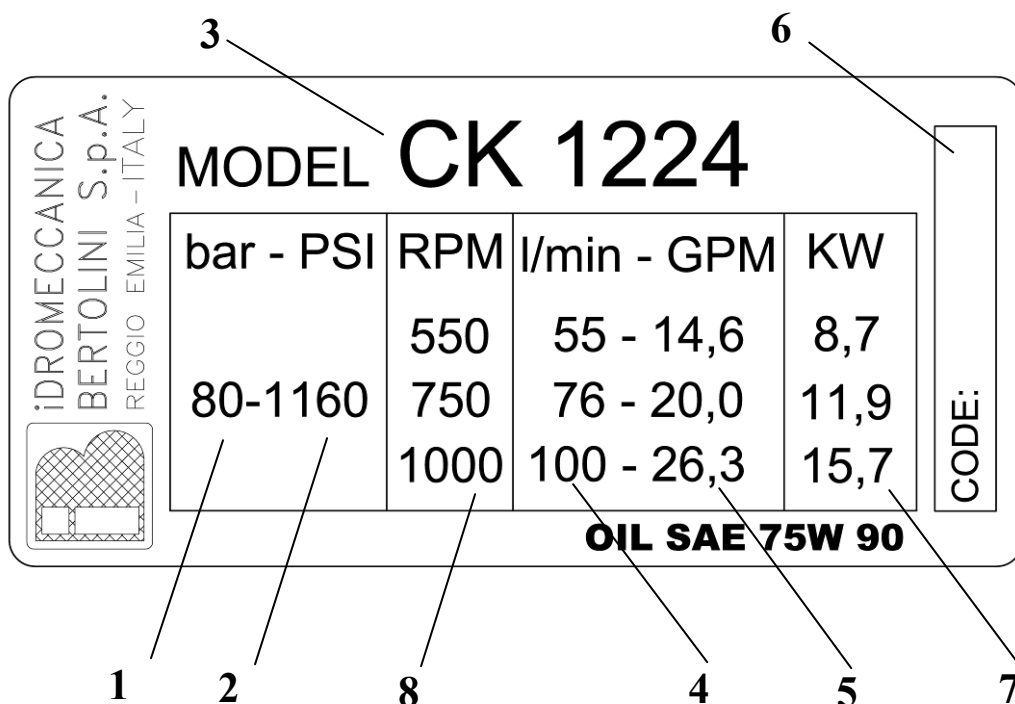

⚠ If the identification label is damaged by use, please contact the seller or an authorized Customer Service for its replacement.

3- TECHNICAL CHART

		PUMP PERFORMANCE							C 300 SERIES					
		PUNPS		MAX RPM	FLOW RATE at max. pressure		MAX PRESSURE		POWER REQUIRED at max. pressure and flow		Shaft Dia. mm	Key Dimens. mm	PISTONS	
		MODEL	PART NUMBER		rpm	l/min	GPM	bar	PSI	KW			HP	N°
CK 1224	73.8500.97.3	1000	100	26,3	80	1160	15,7	21,0	35	10 x 8 x 55	3	45		
CK 1229	73.8501.97.3	1000	126	33,2	80	1160	19,7	26,4			3	45		
CK 1235	73.8502.97.3	1000	149	39,4	80	1160	23,4	31,4			3	45		
CK 1519	73.8503.97.3	1725	84	22,2	105	1523	17,4	23,3			3	38		
CK 1523	73.8508.97.3	1725	98	26,0	105	1523	20,3	27,2			3	38		
CK 1525	73.8504.97.3	1450	98	26,0	105	1523	20,1	27,0			3	38		
CK 2214	73.8509.97.3	1725	61	16,2	150	2175	18,1	24,2			3	30		
CK 2216	73.8510.97..3	1725	69	18,3	150	2175	20,4	27,3			3	30		
CK 2220	73.8506.97.3	1450	79	20,9	150	2175	23,3	31,3			3	30		
CKL 2226	73.8616.97.3	1450	96	25,4	150	2175	28,3	38,0			3	30		
CKL 2230	73.8617.97.3	1450	113	29,9	150	2175	33,3	44,7			3	30		
CKL 2233	73.8618.97.3	1450	124	32,9	150	2175	36,6	49,1			3	30		
CA 2214	73.8514.97.3	1725	61	16,2	150	2175	18,1	24,2			3	30		
CA 2216	73.8515.97.3	1725	69	18,3	150	2175	20,4	27,3			3	30		
CA 2220	73.8516.97.3	1450	79	20,9	150	2175	23,3	31,3			3	30		
CA 1523	73.8513.97.3	1725	98	26,0	105	1523	20,3	27,2			3	38		
CA 1525	73.8512.97.3	1450	100	26,4	105	1523	20,6	27,6			3	38		
CPQ 9020	73.8626.97.3	1000	87	22,9	200	2900	34,1	45,7			3	30		
CPQ 1316	73.8628.97.3	1000	125	33,0	160	2320	39,2	52,6			3	36		
CPQ 1413	73.8629.97.3	1000	140	37,0	130	1885	35,8	48,0			3	40		
CPQ 1613	73.8630.97.3	1000	154	40,7	130	1885	39,4	52,8			3	40		
C 1248	76.8005.97.3	900	199	52,7	80	1160	31,3	42,0			6	45		
C 1258	76.8000.97.3	900	251	66,3	80	1160	39,4	52,9			6	45		
C 1538	76.8002.97.3	1725	166	44,0	105	1523	34,3	46,0			6	38		
C 2225	76.8003.97.3	1725	104	27,4	150	2175	30,6	41,0			6	30		
C 2233	76.8004.97.3	1725	138	36,6	150	2175	40,8	54,6			6	30		

3.1. IDENTIFICATION OF COMPONENTS

CK 3003-CA 316-CPQ

1. Identification label
2. Oil filling plug with dipstick
3. Pump shaft
4. Outlet
5. Inlet
6. Inlet valve cover
7. Outlet valve cover
8. Pump head
9. Crankcase
10. Mounting brackets
11. Bearing supports
12. Oil drain plug
13. Oil level plug

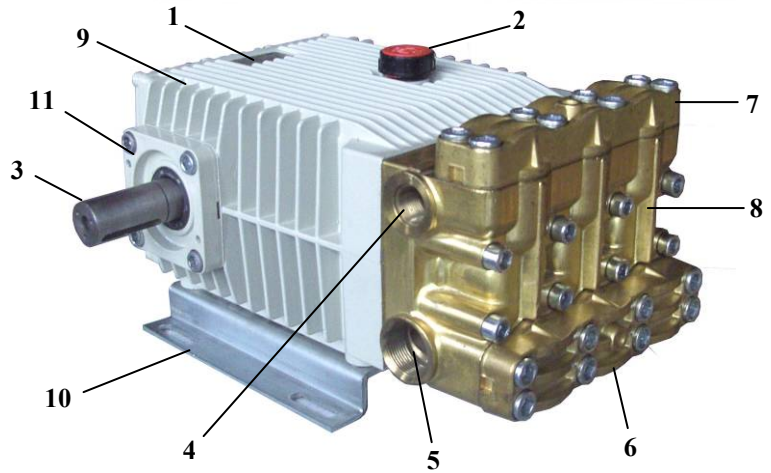

C 3006

The oil drain plug is on the shaft opposite side

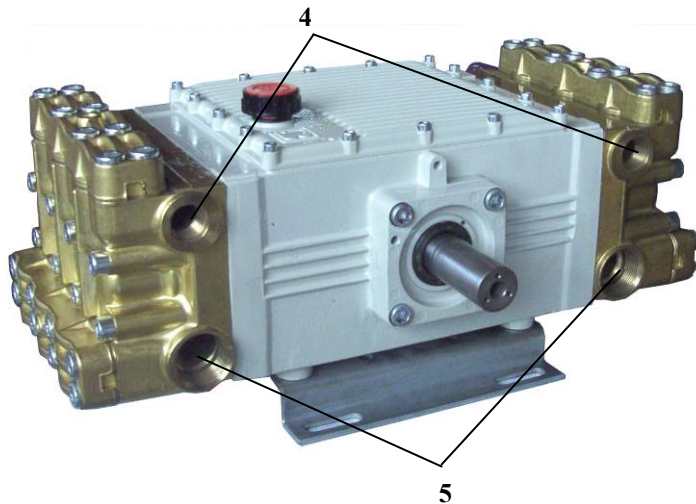
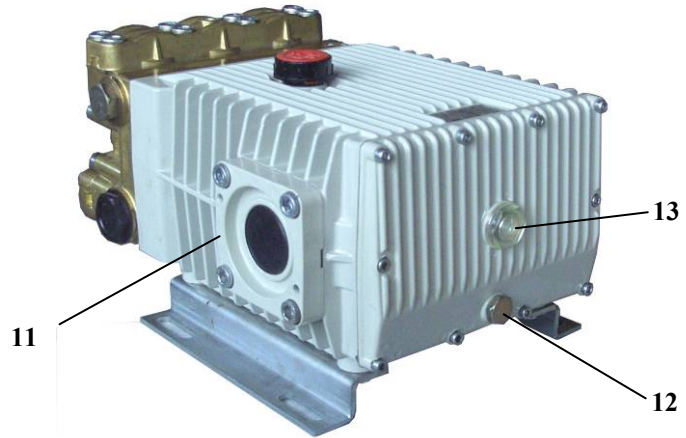

3.2 AIM OF USE

- The pump is exclusively devoted to:
 - Be used with clean water and temperature from +4°C up to +60°C, for not alimentary use.
 - Be used with detergents in watery solution.
- The pump cannot be used with:
 - Watery solutions with higher level of stickiness and density in comparison of water.
 - Solutions of chemical products that you are not sure can be compatible with the pump materials.
 - Seawater or high saline concentration.
 - Any kind of fuels and lubricants.
 - Inflammable liquids or liquefied gas.
 - Fluids for alimentary use.
 - Any kind of solvents and diluents.
 - Any kind of varnish.
 - Fluids with temperature lower than 4°C or higher than 60°C.
 - Fluids containing grains or solid suspended particles.
- The pump cannot be used to wash persons, animals, electric equipment, delicate objects, the pump itself or the system where the pump is installed.
- The pump cannot be used in environments presenting particular conditions, as, for instance, corrosive or explosive atmospheres.

Any different use must be considered improper.

The producer is not responsible for any damages deriving from improper or incorrect use.

4- INSTALLATION NORMS

The Bertolini pumps, concerning security, comply with the rule UNI EN 809 and are destined to be coupled, directly or through a countershaft, with an electric motor, hydraulic motor or gasoline engine.



The machine or the system where the pump is located must be perfectly built observing the current safety rules in the country where the machine is installed.

For Europe this is guaranteed by the CE mark and by the declaration of compliance of the machine manufacturer.



A correct installation is the decisive factor for a good operation and for a long life of the pump. The 90% of problems and malfunctions come from:

- Inadequate coupling between pump and engine/motor;
- Inadequate sizes of the inlet circuit;
- Inadequate quality or incorrect calibration of the pressure relief valve or unloader valve.

***Idromeccanica Bertolini* declines all responsibility if the following regulations are not complied with:**

4.1 PUMP ENGINE COUPLING

The system manufacturer will undertake to choose the correct sizes of the driving gear, considering also the risks towards people the chosen system can cause.



In case of connection with electric motors, all the regulations indicated by the rules EN 60204.1 against electric risks must be followed.



In particular all the moving parts must be properly protected, in compliance with the machines directive 2006/42/CE or the country current rules, in order to prevent their accidental contact with body parts.



If the pump shaft has a double P.T.O., the one that is not used must be protected with a proper shield.



In case of damage or breaking of the shaft protection or of the shaft, immediately stop the system and contact a qualified technician.



When using, do not lean hands or feet on the shaft protection.

- In order to assure a correct lubrication of all the moving parts, the pump must operate keeping the plungers axle in horizontal position.
- The pump-engine/motor unit must be properly fixed on a sufficiently large and strong base.
- All the electric wiring must be carried out by qualified technicians.
- In case of direct drive with the engine/motor make sure that:
 - The engine/motor shaft is on the same axle as the pump shaft.
 - The key is as long as prescribed.
 - The coupling has the proper size.

- In case of drive by a gearbox you have to follow the same previous recommendations of the coupling between engine/motor shaft – primary shaft and secondary shaft – pump shaft.
- In case of drive by pulleys check:
 - There is not any gap between shafts and pulleys.
 - The pulleys are parallel and aligned.
 - The belts are strained with the correct value. An excessive strain of the belts will lead to a premature wear of the bearings.

4.2 INLET CIRCUIT

- The design of the inlet circuit must be done in order to prevent the cavitation. In the following chapter 5.2 D is described how to dimension the inlet circuit. In any case it is necessary to verify with a pressure device or a pressure gauge in the inlet fitting of the pump (point 7 in the installation scheme), that the pressure doesn't fall under -0,2 bar.
- The inlet line must have a **filter** with a filtering degree between 50 and 80 mesh as indicated in the chapter 5.2B. The filter produces a hydraulic loss that reduces the pump suction capacity. For this reason the filter must have an appropriate flow rate. It is recommended to use a filter with a capacity 2,5 times the pump flow rate.
- **The inlet pressure of the pump does not have to exceed 5 bar.**
- The diameter of the filter pipes must not be lower than the diameter of the pump inlet pipes.
- The filter must be installed as close as possible to the pump in an easily accessible position, and must be inspected before each pump starting.
- In case of pressure feed through a centrifugal pump, make sure the provided capacity is at least 1.5 times more than the pump capacity.
- In case of feed from a tank follow these instructions:
 - The tank must have a minimum capacity of four times the pump capacity per minute.
 - The pump inlet pipes must be located near the bottom of the tank, with a water head of at least 200 mm, avoiding the formations of siphons.
 - The suction area must be protected by turbulence caused by the tank feeding pipe, and by the return pipelines, through special bottom closed bulkheads.
 The tank must be provided with the safety devices indicated in the chapters 5.2 E and 5.2 F.
- We suggest carrying out the piece of pipeline directly next to the pump with flexible hoses, suitable to isolate the rest of the system from the vibrations caused by the pump-engine/motor unit.
- Use only stiff or flexible strengthen pipes for anti-deflection.
- The inlet pipelines must be as straight as possible, reducing as much as possible curves, elbows and rough fluctuations of section.
- Do not use oil-pressure pipe fittings, 90° elbows, fittings with multiple ways, wing nuts etc.
- Do not use foot or one-way valves.
- Do not install devices for detergent sucking in the inlet circuit of the pump.
- Make sure the inlet line, before being connected to the pump, is perfectly clean inside.

4.3 HIGH-PRESSURE CIRCUIT

- ⚠ All the parts of the high-pressure circuit must have minimum performances (pressure and flow) at least 30% higher than the performances achievable by the pump.
- ⚠ The high pressure circuit must be provided of a **pressure regulating valve** and a **relief valve** as indicated in the chapter 5.2 A and a **pulsation dampener** as indicated in the chapter 5.2 C
- ⚠ The pressure relief valve and the regulating valve must have the label taking the name of the manufacturer and the values of the max pressure, flow and temperature allowed.
- ⚠ In case of repeated operations of the pressure relief valve, immediately stop the pump and check the system with the help of a skilled technician.
 - Do not connect the pressure relief valve by-pass and the regulating valve by-pass to the inlet line.
 - Especially in presence of an automatic regulating valve we suggest to fit, immediately after the pump, a properly sized pulsation damper.
- ⚠ The pulsation damper must be sized according to the pump performances and to the instructions provided by the manufacturer.

On the body the following data must appear: manufacturer brand, max pressure allowed, test pressure, pre-charge pressure, capacity and manufacturing date. When tests are foreseen, the serial number and the test initials required in the country where the machine is installed must appear as well.
- ⚠ We recommend to make the first piece of pipeline with flexible hoses, able to isolate the rest of the system from the vibrations caused by the pump-engine/motor unit.

The flexible hoses must be mechanically seamed by the manufacturer and must have the stamp with the name of the manufacturer, the manufacturing date, the max. pressure and the maximum temperature admitted.

 - Use pressure gauges in glycerine bath able to stand pulsating pressures.
 - The high pressure circuit must be provided of a device to by-pass without pressure when starting the pump

The high pressure circuit, so as explained for the inlet circuit, is subject to pressure losses caused by its structure; therefore it is normal that the working pressure is lower than the pressure valve of the pump head.

- 1) Level switch;
- 2) Thermostat;
- 3) Minimum tank capacity:
pump flowX4;
- 4) Watertight bulkheads on the bottom;
- 5) Suction line
minimum dia. 47mm for CK3006
minimum dia. 33mm for CK3003;
- 6) Inlet filter;
- 7) Pressure switch to control
inlet;
- 8) Suction collector with
minimum diameter 33mm;
- 9) Safety valve;
- 10) Safety valve BY-PASS;
- 11) Pressure regulating
valve;
- 12) Regulating valve BY-PASS;
- 13) Outlet;
- 14) Pressure gauge;
- 15) Pulsation dampener;
- 16) By-pass line;
- 17) tank feed;
- 18) Section valve to by-pass the flow
when starting the pump
3/4" for pumps CK 3003
1" for pumps CK 3006
- 19) Minimum dia. 25mm;
- 20) Minimum dia. 18mm.

4.5 ERRORS TO AVOID

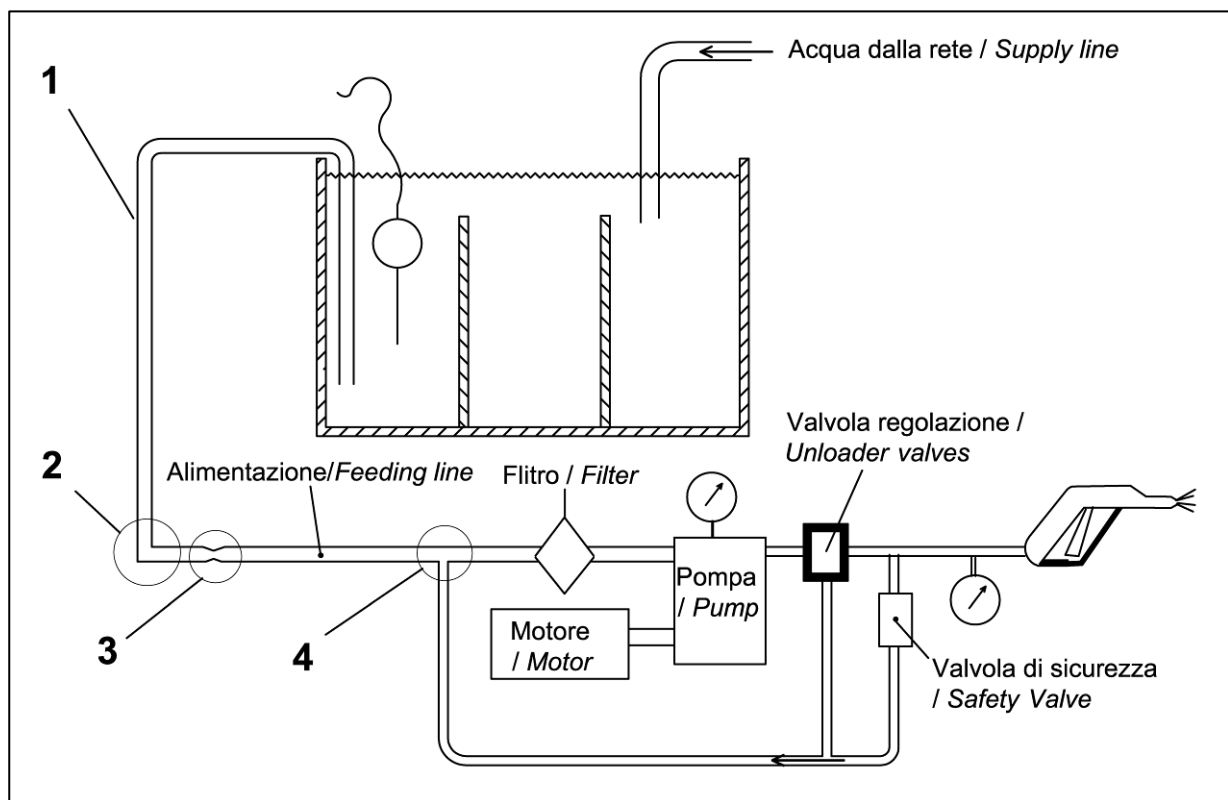

- 1) Avoid for not having "siphon" effect
- 2) Avoid to install elbows 90°
- 3) Avoid diameters reductions;
- 4) Never connect the by-pass line with return on the inlet line.

5- SAFETY DEVICES AND MALFUNCTIONING PREVENTION

5.1 SAFETY DEVICES

The system incorporating pump must always be provided with the following safety devices:

- **Safety valve:** It is a pressure relief valve, properly calibrated, able to discharge the excessive pressure in case of fault in the high-pressure circuit.
- **Pump shaft protection:** This kind of protection keeps the operator from accidental contact with the moving parts of the shaft and the driving.
- **Pressure regulation valve:** This valve permits to regulate the working pressure and allows the excessive fluid to flow back in the reservoir, preventing dangerous pressures.

5.2 MALFUNCTIONING PREVENTION

5.2 A) OVERPRESSURES PROTECTION:

The pump is a volumetric type, and the same quantity of fluid always comes out at every shaft turn. Since the fluids are incompressible, if fragments accidentally clog the nozzle, keeping the fluid out, the plungers would push towards a solid component. If a protection valve is missing, the pump would immediately destroy itself.

Safety valve.

A safety valve of proper quality and size prevents this kind of problems.

If during the normal use (e.g. with a washing gun and a lance) the supply is frequently interrupted, the water circulates through the pressure relief valve at the set pressure, causing overheating and consequently damaging the pump.

By-pass and Pressure Regulating Automatic Valve.

An automatic valve reduces this problem because, in this kind of valve, the water circulates at a very low pressure, and the water overheats in a longer time.

5.2 B) PROTECTION FROM ABRASIVE PARTICLES

Water always has impurities and abrasive particles, also when it is drinking water.

The abrasive particles not only damage the seals, but also wear the check valves, the regulating valve and the nozzle, in a very short time.

A properly sized filter, installed next to the pump, assures a long life to all the system.

Remind the filter must be always efficient, clean and periodically controlled depending on the use of the pump.

5.2 C) PROTECTION FROM PULSATIONS

A pressure damper charged at 50-60% of the working pressure damps the whole hydraulic system vibrations, thus reducing the stress on the system.

5.2 D) PROTECTION FROM CAVITATION (NPHSr)

The cavitation is generated by the formation of gas pockets in the supply circuit, and wears the gaskets and the metal parts of the pump. The clearer consequence is a continuous or intermitting hammering, coming from the pump.

Performances, pressure and flow often reduce or become intermittent.

All the fluids tend to generate steam and this is particularly clear when temperature is rising

and when pressure is falling in the suction line.

During the return run the plungers generate a depression which flow the water into the pumping chambers; as higher is the resistance encountered by the water while running from the reservoir to the pump, as bigger is the value of the depression created by the pump. Consequently the cavitation risk also increases.

This resistance is due to two decisive factors.

- Concentrated pressure losses: due to the presence, along the line, of elbows, curves, fittings, taps, filter, etc. Being an obstacle to the regular water flow, they offer a resistance mainly dependent on their size and shape.
- Distributed pressure losses: due to the friction generated between the moving water and the pipes sides. The value of these losses is proportional to the pipe length, rises when the internal roughness of the pipe increases and, at the same water capacity, increases when the internal diameter of the pipe decreases.

Other pressure losses are due to: water temperature, difference in height between the pump and the water level in the tank

To project the plumbing should be considered that the pump inlet pressure is ever lower than the pressure at the beginning of the suction line.

To prevent the cavitation, the minimum difference in height Hz between the pump and the water level in the tank must respect the following condition:

$$H_z > (NPSHr+C)+H_1 + H_2 - (H_{atm} - H_3) \quad (\text{m \& \text{ }^\circ\text{C}) \text{ or } (\text{ft \& \text{ }^\circ\text{F})}$$

Where:

NPSHr: net positive suction head required. The value of NPSHr of the pump can be obtained by the following table 1:

H_z = minimum difference in height (positive or negative) between the pump and the water level in the tank

C = 0,5m (1,65 ft);

H₁ = hydraulic losses due to pipes and fittings (see tables 2 and 3);

H₂ = hydraulic losses depending on the water temperature (see table 4)

H_{atm} = atmospheric pressure at the see level = 10,33m (33,9 ft)

H₃ = hydraulic loss depending on elevation above see level (see table 5)

CALCULATION DATA

Table 1 *NPHSr value with the RPM of the pump*

RPM	NPSHr (m)	NPSHr (ft)
900	6,5	21,3
1450	6,8	22,3
1725	7	23

Table 2 *Equivalent length of pipe fittings, of different size in m (ft) of steel pipe*







		1/2"	3/4"	1"	1"1/4	1"1/2			1/2"	3/4"	1"	1"1/4	1"1/2
	ft	0,41	0,54	0,69	0,90	1,05		ft	1,67	2,21	2,81	3,70	4,31
	m	0,12	0,16	0,21	0,27	0,32		m	0,51	0,67	0,86	1,13	1,31
	ft	18,50	24,50	31,20	41,00	48,00		ft	3,71	4,90	6,25	8,22	9,59
	m	5,64	7,47	9,51	12,50	14,63		m	1,13	1,49	1,91	2,51	2,92
	ft	9,30	12,30	15,60	20,50	24,00		ft	0,93	1,23	1,56	2,06	2,40
	m	2,83	3,75	4,75	6,25	7,32		m	0,28	0,37	0,48	0,63	0,73
	ft	0,78	1,03	1,31	1,73	2,15		ft	3,33	4,41	5,62	7,40	3,08
	m	0,24	0,31	0,40	0,53	0,66		m	1,01	1,34	1,71	2,26	0,94

Table 3 *Losses calculated for 10m (10ft) of steel pipe of different size and flow rate*

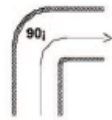
GPM	L/min	1/2"	3/4"	1"	1"1/4	1"1/2
1	3,785	0,2				
2	7,6	0,50				
2,1	8	0,60				
3	11,4	1,10	0,3			
3,2	12	1,40	0,35			
3,5	13,2	1,50	0,4			
4	(15)	1,70	0,45			
4,8	18	2,50				0,6
5,5	(21)	3,4	0,7	0,1		
6,3	24	4,3	1,1	0,2		
8	(30)	6,4	1,5	0,4		
9,2	35	8,5	1,9	0,6		
10,6	40	11,1	2,6	0,8	0,1	
13,2	50		3,7	1,2	0,3	
16	(60)		5,5	1,5	0,4	0,1
18,5	(70)		7,5	1,8	0,5	0,2
21	(80)		9,5	2,2	0,6	0,3
26,5	(100)			4,5	1,2	0,6
31,5	(120)			8,5	2,2	1,1
37	(140)			12,8	3,5	1,5
40	(150)				3,8	1,8

Table 4 *Suction loss depending on the water temperature*

°C	°F	m	ft	°C	°F	m	ft
10	50	0,08	0,26	55	131	1,80	5,91
15	59	0,12	0,39	60	140	2,00	6,56
20	68	0,20	0,66	65	149	2,60	8,53
							10,8
25	77	0,28	0,92	70	158	3,30	3
							15,0
30	86	0,40	1,31	75	167	4,60	9
							16,4
35	95	0,52	1,71	80	176	5,00	0
							19,6
40	104	0,70	2,30	85	185	6,00	9
							24,2
45	113	0,92	3,02	90	194	7,40	8
							30,5
50	122	1,20	3,94	95	203	9,30	1

Table 5 Loss depending on elevation above see level

Altezza Elevation Haut Altura		Perdita Loss Perte Pérdida		Altezza Elevation Haut Altura		Perdita Loss Perte Pérdida	
m	ft	m	ft	m	ft	m	ft
500	1640	0,55	1,80	2000	6562	2,2	7,22
1000	3281	1,1	3,61	2500	8202	2,75	9,02
1500	4921	1,65	5,41	3000	9843	3,3	10,83

CALCULATION DATA

Calculation example for pump CK 1229 installed 500 m above see level

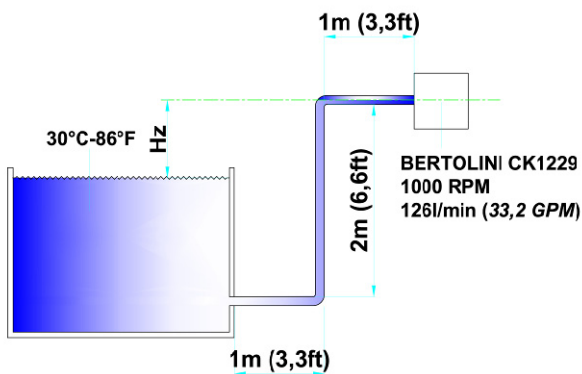

Pipes and fitting dimensions: G1" 1/4

Pipe length (drawing)	1+1+2=	4,00 m
	3,3+6,6+3,3=	13,20 ft
Equivalent length of fittings (table2)	2X1,13=	2,26 m
	2X3,7=	7,40 ft
Total length		6,26 m
		20,60 ft
H1 (tab.3)	2,5X6,26/10=	1,57 m
	2,5X20,6/10=	5,15 ft
H2 (tab.4)	30°C	0,40 m
	86°F	1,31 ft
H3 (tab.5)	500m	0,55 m
	1640ft	1,80 ft
NPHSr (tab1)	RPM 1000	6,60 m
	RPM 1000	21,65 ft
	$H_z > (6,8+0,5)+1,57+0,4-(10,33-0,55)=$	-0,72 m
	$H_z > (22,3+1,65)+5,15+1,31-(33,9-1,8)=$	-2,34 ft

The calculation show that the pump can suck from 0,72 m (2,34 ft) height. If Hz would be positive, the pump should be feed under pressure.

5.2 E) PROTECTION FROM OVERHEATING

Also the operation with very hot water causes cavitation risks and wears the seals, so it must be avoided.

Reduction of the motor R.P.M.

Especially if the pump is driven by an electric motor driven by an inverter, it is necessary to install a device able to reduce the engine/motor R.P.M. and consequently the pump capacity, when the bypass valve is operating. With this device the water temperature is reduced.

A thermostat installed inside the tank indicating the achievement of too high temperatures or, when possible, stopping the motor, is another recommended safety system.

5.2 F) PROTECTION FROM POOR OR NON SUPPLY.

The pump does not have to run dry to avoid the wear of the seals and the overheating causing the pistons failure, irreparably damaging the pump.

A level switch indicating lack of water in the reservoir, or, when possible, stopping the engine/motor is a recommended way to prevent the dry operation.

Next to the inlet pipe a **Pressure switch** must be installed, provided with an alarm signal, or if possible able to stop the engine/motor when the inlet pressure decreases under the value of incipient cavitation.



In case the level switch, the thermostat or the pressure switch cause the engine/motor stop, the switch to be used must be with manual starting, to avoid the spontaneous re-starting of the engine/motor.

5.2 G) ENERGY SAVING / PUMP CORRECT USE

It is quite normal that the pump flow is oversized in comparison with the real use needs.

For a correct running of the system, the water circulated through the regulating valve does not have to exceed 10-15% of the pump flow.

Otherwise, besides the useless energy waste, a water overheating will be generated in the supply tank, increasing the cavitation risks. Moreover, all the circuit parts, and in particular the regulating valves, are subject to a continuous and extreme stress.

It is therefore recommended to adapt the pump capacity to the actual system needs, reducing the pump R.P.M.

6 FAQ

Question: How much should you reduce the pump R.P.M. in order to get less flow?

Answer: Required R.P.M. = Expected flow x $\frac{\text{Max R.P.M. allowed}}{\text{Max allowed flow}}$

Question: Which diameter the engine/ motor pulley should have to achieve these R.P.M.?

Answer: External diameter of the motor pulley =
External diameter of the pumps pulley x $\frac{\text{pump R.P.M.}}{\text{Engine/motor R.P.M.}}$

Question: What's happening if it is not possible to replace the engine/motor pulley?

Answer: External diameter of the pump pulley =
External diameter motor pulley x $\frac{\text{engine/motor R.P.M}}{\text{Pump R.P.M.}}$

Question: If the engine/ motor is running at lower R.P.M. than the max. R.P.M indicated in the label, which is the maximum flow rate to achieve?

Answer: Attainable maximum flow =
Engine/motor R.P.M: x $\frac{\text{Max. flow indicated in the label}}{\text{Max. R.P.M. indicated in the label}}$

Question: What is the approximate power required to achieve the max. performances allowed?

Answer: Required power (kw) = $\frac{\text{Max flow (L/min)} \times \text{Max pressure (bar)}}{524}$

Our customer service is at Your disposal for any further information.

7- SETTING UP

Preliminary checks

- Check the inlet line is connected and sealed.
- Check the filter is clean.
- Check all the seizure valves on the inlet line are open and the water normally flows to the pump. **Do not run the pump dry.**
- Check that all discharge pipes are connected to use
- The coupling allowances between the pump shaft and the driving (semi-coupling misalignment, cardan inclinations, shaft-pulley gap, belts strain, etc.) remain into the limitations foreseen by the driving manufacturer.
- Replace the oil plug without vent (red colour) by the oil plug with vent. This operation could have already been carried out by the producer of the machine incorporating the pump.
- With pump at a standstill, check that the oil level corresponds to the middle of the oil level light. The oil level can be also checked by unscrewing the plug with vent: the correct level must be included between the two notches on the rod. Remember that the oil level must be always checked with pump at a standstill and completely cooled down.
- Before starting the pump, carefully read the instruction of this manual and the instructions of the machine incorporating the pump.
- Make sure that the pump moving parts are suitable protected and that they cannot be accessed by unauthorised personnel.
- In case of use at very low temperature, make sure that there is no ice inside the pump.
- Check the cleaning of suction filter.
- Make the preliminary operations prescribed by the producer of the machine incorporating the pump.

CAUTION

- **The pump cannot be commissioned if the machine that incorporates it does not conform to the safety norms established by European Directives. This conformity is guaranteed by the presence of the CE marking and by the Declaration of Conformity of the Producer of the machine incorporating the pump.**
- Don't use the pump in case:
 - it has undergone strong hurts;
 - there are oil leaks;
 - there are visible water leaks.In these cases have the pump be checked by an **Engineer**.
- Have an **Engineer** to make the checks expected by the extraordinary maintenance.

7.1 Starting procedure

- Start the pump without any pressure, after setting to zero the pressure regulator or opening the possible by-pass devices.
 - Check the RPM do not exceed the max. value indicated in the label.
 - Before taking the pressure to the required value, wait until all the air in the circuit has come out and the water comes out with a continuous and firm jet.
-  During the winter months, and in case of intense cold, before starting the pump, check the possible presence of ice in the inlet and in the outlet circuits.

Do not run the pump before the circuit has been completely defrosted.

7.2 Operation



Caution! The high pressure jet, if incorrectly used, may damage persons, objects and animals.

No operation must be carried out when the system operates, pressure regulation apart. If, for instance, it is necessary to tighten a plug, or a fitting, to control a high-pressure hose, or other, **before carrying out the operation, reset the pressure and stop the pump.**

- The water jet must be always directed to the operating area, even during tests and preliminary controls.
- Do not run the pump before having directed the jet towards the operating area.
- The operating area concerned with the jet must be forbidden and cleared of the objects which, if bumped by the pressure jet, can be damaged or blow away.
- Pay attention to the trajectory of the fragments removed by the water jet and, if necessary, use proper bulkheads to protect anything could be accidentally struck by the fragments.
- Too high pressures may damage the objects that you require to wash; we recommend carrying out preliminary operating tests (working pressure, distance from the nozzle, from the object, etc.).

Idromeccanica Bertolini S.p.A. declines any civil or criminal liability, for damage or accidents to persons or objects, as may arise from the improper use of the pump and other relevant accessories in the system where the pump is installed.

7.3 Water leaks from seals

- In case a little quantity of water leaks from the discharge area located under the crankcase, this leak (some drops for minute) is a normal factor for the correct pump operation.

7.4 Pump Shutdown

- Stop the pump only after setting to zero the pressure using the pressure regulator or the by-pass devices.
- If chemical products have been used, run the pump with clean water for a few minutes. Then, empty the pump, disconnecting the suction and by running the pump for about 20 seconds.
- During the winter months, when the pump is subject to freezing conditions, or when you foresee a long time of no operation, it is necessary to empty all the circuit from the fluid residues, or mix clean water with anti-freeze liquid in correct proportions.

8- TROUBLESHOOTING

FAULT	CAUSE	REMEDY
When starting the pump does not supply water and does not make any noise	<p>Not enough water capacity in the inlet circuit</p> <p>Blocked valves</p> <p>The outlet line is closed and does not allow the air in the head to come out</p>	<p>Check the circuit and water level in the reservoir.</p> <p>Check and replace if necessary.</p> <p>Drain the outlet line until the water regularly comes out</p>
The pump is noisy and beats improperly	<p>Pump is sucking air</p> <p>Inlet circuit of improper size</p> <p>Jammed or worn valves</p> <p>Worn high pressure seals</p> <p>Malfunctioning of the pressure regulator</p> <p>Problems with driving</p> <p>The number of revolutions is higher than the value indicated on the label</p>	<p>Check suction circuit and possible air ingress</p> <p>Check the correct size of the inlet circuit.</p> <p>Check the filter cleaning</p> <p>Check and if necessary replace</p> <p>Check alignment, gaps, calibration.</p> <p>Restore the proper number of revolutions</p>
Vibrations or strokes on the pipeline	<p>Air intake</p> <p>Malfunctioning of the pressure regulator</p> <p>The pressure regulator by-pass line is undersized or obstructed</p> <p>Blocked valves</p>	<p>Check the suction circuit and possible air ingress</p> <p>Check and if necessary replace.</p> <p>Check the correct sizes</p> <p>Check and/or replace if necessary..</p>
The pump normally runs, but does not achieve the indicated performance	<p>Inlet circuit of improper size</p> <p>Malfunctioning or not adjusted pressure regulator</p> <p>Nozzle of improper size or worn</p> <p>Worn plunger seals</p> <p>Worn check valves</p> <p>The number of revolutions is lower than the value indicated on the label</p>	<p>Check the correct size of the inlet circuit.</p> <p>Check the filter cleaning</p> <p>Check and/or replace if necessary</p> <p>Restore the proper number of revolutions</p>
The pump is noisy and over-heat	<p>Excessive temperature of liquid</p> <p>The working pressure is higher than the one indicated in the label</p> <p>The number of revolutions is higher than the value indicated on the label</p> <p>Excessive strain of the belts</p> <p>Oil not at its level, contaminated or exhausted</p> <p>Worn bearings</p>	<p>Reduce the water temperature</p> <p>Restore the proper values</p> <p>Check, fill or change if necessary.</p> <p>Replace</p>
Water dripping below the pump	<p>Worn Packings</p> <p>Worn O-Ring plunger retainer</p>	<p>Check and/or replace</p> <p>Check and/or replace</p>
Oil dripping	<p>Worn Oil seal</p>	<p>Check and/or replace</p>
The pressure gauge shows irregular oscillations at high pressure with open lance	<p>Valve with impurities</p> <p>Worn Plunger seal</p> <p>Worn Check valves</p>	<p>Clean the valve and lubricate the parts with grease</p> <p>Check and/or replace</p> <p>Check and/or replace</p>

CAUTION!: nozzle is subject to wear, to be replaced every time your pump will not reach the required pressure; in fact, when worn, enlarging the size of the water hole, the actual flow rate increases and pressure decreases.

9- WARRANTY

The liability of Idromeccanica Bertolini under the period of warranty (12 months from date of shipment) is limited to the replacement of the parts appearing defective according to an examination by Idromeccanica Bertolini.

This warranty is only valid when the fault is ascertained by its technicians, and it shall not apply to improper use or negligence in maintenance of the pump.

This warranty does not apply to the normal wear of the components (plastic rubber parts, seals), and to the labour costs.

This warranty is valid:

- *If the pump is operating within its technical specifications.*

This warranty is not valid:

- *In case of damages caused by bad functioning of the pressure regulator;*
- *If the pump operates without sufficient water in suction;*
- *If the pump operates without oil;*
- *If the pump is damaged for freezing;*
- *If the pump operates for a long time in by-pass.*

USE OF OTHER THAN BERTOLINI SPARE PARTS VOIDS THE WARRANTY

Parts requiring return to factory must be freight prepaid. Parts returned must have factory approval documentation prior to return.

10- MAINTENANCE AND REPAIRS

10.1 Crank gear maintenance and lubrication

- Check at least once a week the oil level using the appropriate stick.
- After 50-100 hours of working it is necessary to change the pump oil with a **SAE 75W90 enriched by the specific additive provided by Idromeccanica Bertolini**. The additive percentage is indicated on the package. This substitution ensures the correct lubrication for all of the rest of the pump life.
- **If the pump is used in humid climates or environments, the water in the air normally tends to condense and to mix with the pump oil, which will assume a typical white colour. In this case it is necessary to check the oil more frequently, and in presence of water immediately change it.**
- In presence of water in the oil immediately check the provenience and replace the concerned seals. Before changing oil accurately clean the crankcase and the shaft, bearings and connecting rods.

CAUTION!: The pump operation with emulsified oil (with water, condensation etc.), reduces the lubrication of the moving parts, causing overheating and premature failures.



Protect the environment from liquids contained in the pump.
Collect and regularly drain the residues; no residue must enter the canalisation net or into the ground.

10.2 Check Valves Service

Disassembly

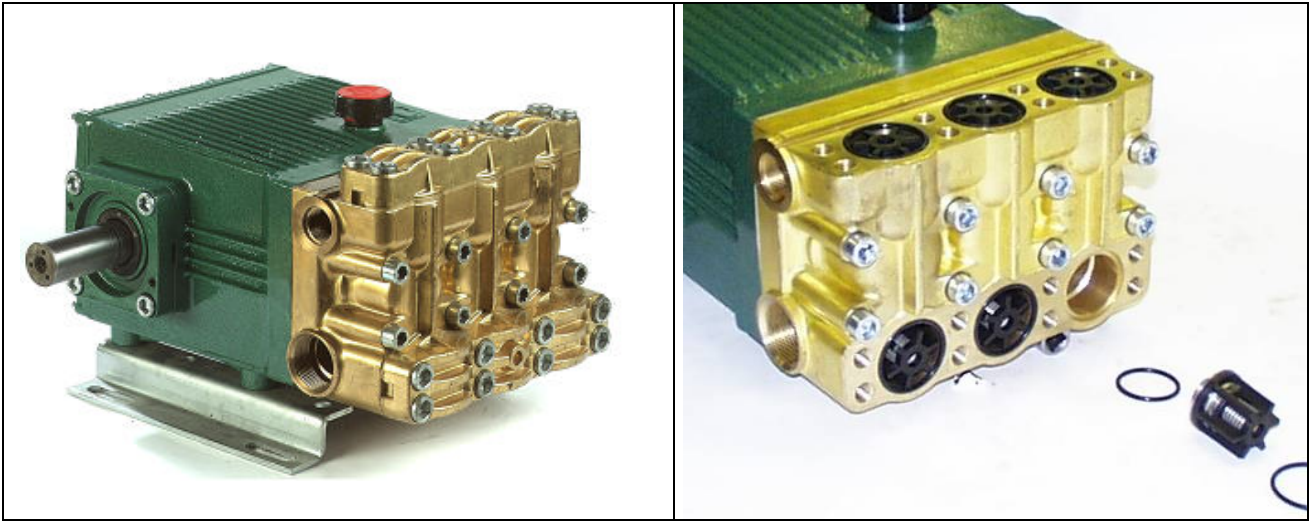

The check valves are easily accessible after removing the two brass caps, each one fixed by 8 M14 screws.

1. Take out the valves and the relevant O-Rings from their seat in the head, using a small screwdriver.
2. Check the housings bottom, on the head, is absolutely smooth and do not present flutings or apparent wear marks.

Checks

3. Check the O-Rings integrity
4. Check the valve springs integrity.
5. Check the poppets are not stuck to their seat and can run within the plastic cages.
6. Check the integrity of the cages and particularly verify the guide are not deformed or damaged by wear.
7. Check the contact areas seat-poppet does not present pitting or wear marks.

Assembly

1. Lubricate the O-Rings with a coat of oil and locate them at the bottom of its housing.
2. Insert the valves in its housing after lubricating with a oil film. Take care the valve is completely perpendicular at the bottom of its housing.
3. Fit the O-Rings between the head and the caps in their seat.
4. Replace the valve caps, and tighten the 16 screws M14 at 108 Nm torque.

10.3 Packing/Seal Service



Disassembly

1. Using a 10mm allen spanner, remove the head screws, and take out the head with a plastic hammer.
2. Extract the packing assemblies using a proper packing extractor (see table at page nr. 29).

If you do not have an extractor you can use expansion pliers and proceed as follows:
The picture represents a generic seals assembly; while the proper composition is shown for every pump model in the instruction sheet attached to the kit.

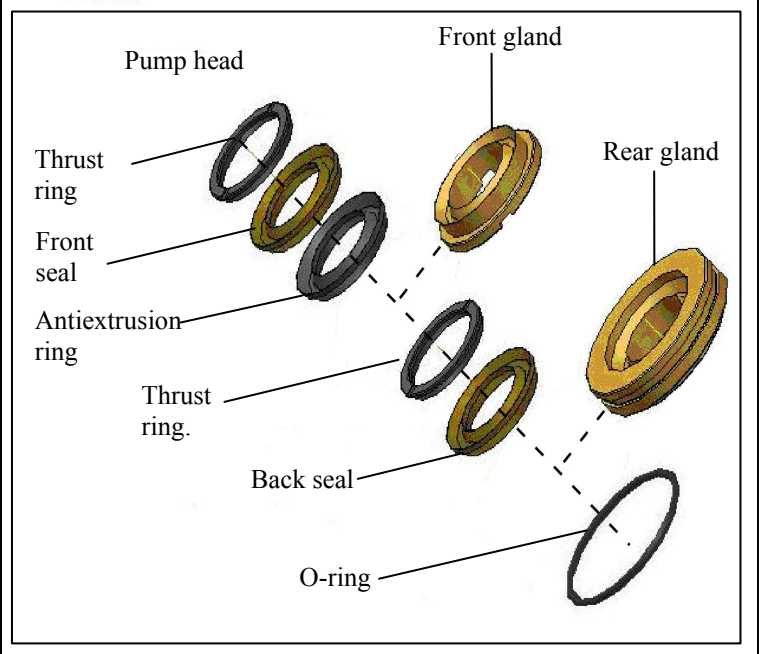

Assembly

1. Lubricate the new seal and install it in the head housing using the proper tool (see chart. page 29) in order to not damage the external edge.
2. Replace the seals or the complete seals assembly as needed; consider that the gland realized in brass must be substituted only in case of clear wear signs.
3. Lubricate the plungers with waterproof grease. Reassemble the head focusing on the plungers and using a plastic hammer until it touches the crankcase. Tighten the 8 M12 screws to 68 Nm torque.

10.4 Oil seals Service

To facilitate this operation use a sharp point screwdriver as shown in the picture below.



Fig.1

Rotate the pump shaft until the plunger corresponding to the oil seal to service is at the bottom dead center (B.D.C.) (picture 2).

Using a sharp point screwdriver (picture 1) and a hammer, punch the metal structure of the oil seal (picture. 3). Rotate the screwdriver by 90° so that the pawl has a secure grip on the oil seal, than push up.

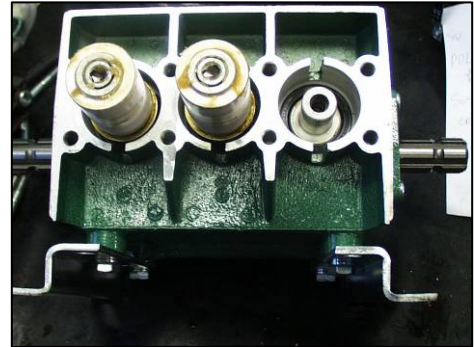

Fig. 2

Mounting the new oil seal after lubricating with oil or grease both the internal and external lips. Push the oil seal into its housing using the proper tools (see table at page 29)

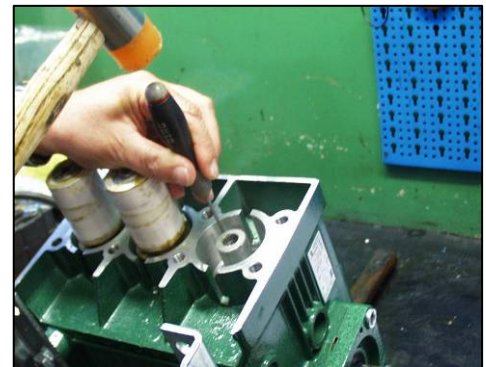

Fig. 3

10.5 Shaft oil seals Service

Disassembly:

STEP 1:

Using a hammer, insert a flat edge screwdriver into the metal structure of the oil seals (picture 4).

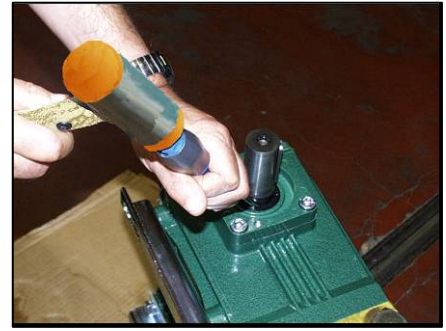

Fig. 4

STEP 2:

Take out the oil seal as indicated in the picture number 5



Fig. 5

Reassembly:

Insert the new oil seal into the proper tool (picture 6) and install it on its housing, using a hammer (picture 7).



Fig. 6

Caution: don't try to mount the oil seals without using the proper tool (see table at page nr.29), because the grooves or the keyway on the shaft would surely damage the sailing lip.



Fig. 7

10.6 Repair tools chart

Function	Pump model	Part number
Extractors to remove the packing seals	Pistons Ø 30	77.1494.97.3
	Pistons Ø 36	77.3362.97.3
	Pistons Ø 38	77.1495.97.3
	Pistons Ø 40	77.3363.97.3
	Pistons Ø 45	77.1178.97.3
Tools to mount the front seals	Pistons Ø 30	77.3008 A-B
	Pistons Ø 36	77.3500 + 773501
	Pistons Ø 38	77.3009 A-B
	Pistons Ø 40	77.3500 + 773502
	Pistons Ø 45	77.3010 A-B
Tools to mount the oil seals on the plunger rods	CK Ø30-38	77.2331 D + 77.2331 B
	CKL	77.2331 H + 77.2331 B
	CK Ø45	77.2331 C + 77.2331 B
	CPQ	77.2331 G + 77.2331 B
	C 3006 Ø30-38	77.2331 D + 77.2331 A
	C 3006 Ø45	77.2331 C + 77.2331 A
Tools to mount the oil seals on the shaft	All	77.2337

Idromeccanica Bertolini can directly supply, on request, all the tools and extractors indicated in the table above.

11- MANUFACTURER'S DECLARATION

Manufacturer's Declaration

Machines Directive 2006/42/CE (Attachment II point B)

Idromeccanica Bertolini S.p.A.
declares under its sole responsibility that the pumps series

- CK 3003-CA 316-CPQ-CK3006

with the serial number
(to be filled in by purchaser according to identification label)

- is manufactured to be incorporated in a machine or to be assembled in with other equipments
to form a machine required by Directive 2006/42/CE

- the producer of the machine that incorporates the pump is the only responsible of the accordance
in every points to this Directive's standards.

Therefore Idromeccanica Bertolini S.p.A. declares that the above pumps must not be put into operation up to the machine in which it will be built-in will be identified and will be declared in compliance with the Directive's standards 2006/42/CE.

Reggio Emilia 03.12.2013

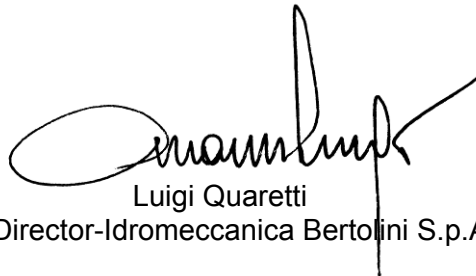

Luigi Quaretti
(Managing Director-Idromeccanica Bertolini S.p.A.)

