

CK3 PP

CARATTERISTICHE - SPECIFICATIONS

IN	DIAMETER	∅	1" 1/2 BSP
	PRESS.	Min.	- 0.2 bar - 3 PSI
		Max.	6 bar 87 PSI
TEMP.	Max.	60° C. 140° F.	
OUT	DIAMETER	∅	3/4 BSP
SHAFT		∅	35 mm
OIL	SAE 30 30 W		2.8 litri 0.74 U.S.G.
PESO WEIGHT		Kg lbs	32 / 70.4



OPTIONAL

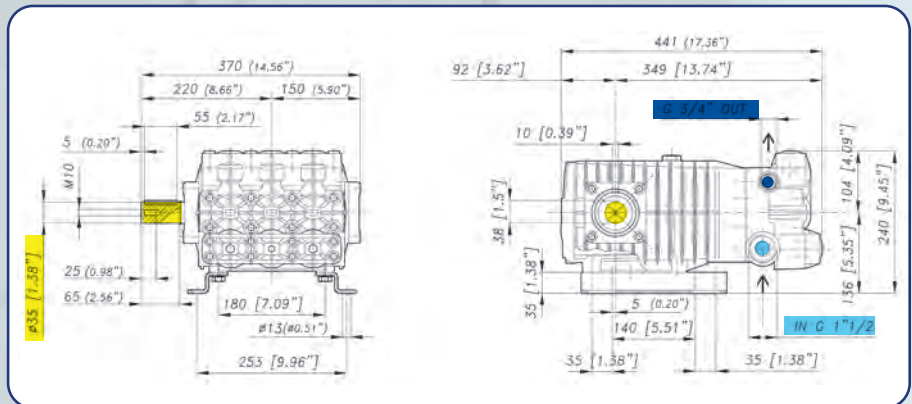

CARATTERISTICHE - FEATURES

PERFORMANCE CHART

MODELLO MODEL CODICE CODE	MAX		PRESS		RPM 550				RPM 700				RPM 900				PIST. CORSA PLUNG. STROKE	
	L/min	GPM	Bar	PSI	L/min	GPM	KW	HP	L/min	GPM	KW	HP	L/min	GPM	KW	HP	Dia. mm	mm
CK 90 PP 73.5105.97.3	88	23.2	50	725	57	14.9	5.5	7.4	70	18.6	6.9	9.3	88	23.2	8.6	11.6	45	22
			60	870	56	14.9	6.6	8.9	70	18.5	8.2	11.1	87	23.1	10.3	13.8		
			70	1015	56	14.8	7.7	10.3	70	18.4	9.6	12.8	87	23.0	11.9	16.0		
CK 115 PP 73.5106.97.3	112	29.6	50	725	72	19.0	7.1	9.5	89	23.6	8.8	11.8	112	29.6	11.0	14.7	45	28
			60	870	72	18.9	8.4	11.3	89	23.5	10.5	14.1	111	29.4	13.1	17.6		
			70	1015	71	18.8	9.8	13.1	89	23.4	12.2	16.3	111	29.2	15.2	20.4		

CARATTERISTICHE - FEATURES

PERFORMANCE CHART

MODELLO MODEL CODICE CODE	MAX		PRESS		RPM 450				RPM 500				RPM 550				PIST. CORSA Dia. mm mm	
	L/min	GPM	Bar	PSI	L/min	GPM	KW	HP	L/min	GPM	KW	HP	L/min	GPM	KW	HP	Dia. mm	mm
CK 110 PP 73.5102.97.3	102	26.9	50	725	88	23.2	8.6	11.6	95	25.2	9.4	12.5	102	26.9	10.0	13.4	45	40
			60	870	87	23.1	10.3	13.8	95	25.0	11.2	15.0	101	26.7	11.9	16.0		
			70	1015	87	22.9	11.9	16.0	94	24.9	13.0	17.4	101	26.6	13.8	18.6		
CK 120 PP 73.5103.97.3	112	29.6	50	725	96	25.5	9.5	12.7	105	27.7	10.3	13.8	112	29.6	11.0	14.7	45	44
			60	870	96	25.4	11.3	15.2	104	27.5	12.3	16.5	111	29.4	13.1	17.6		
			70	1015	96	25.2	13.1	17.6	104	27.4	14.3	19.1	111	29.3	15.2	20.4		